

AIR-DRIVEN LIQUID PUMPS



AIR-DRIVEN GAS BOOSTERS



Control Valves and Components
(For Process, Wellhead and Safety Shutdown Systems)



HIGH PRESSURE VALVES
FITTINGS, TUBING & NIPPLES



Hydraulic & Pneumatic Power Unit



CONTACT

E-mail: sales@pascal-tech.cn

Web: www.pascalmexico.com

Technical Support : +86 18854617560 (WhatsApp)

Add: No.264 Huamulan Street, Donglai Street, Longkou City, Yantai City,
Shandong, China

Pascal (Yantai) Petroleum Technology Services Limited

PASCAL
China's Premium Manufacturer of High-Pressure Fluid Pumps & Valves

We specialize in independent R&D and design of engineering-supporting products to fulfill clients' tailored needs.

PASCAL's pumps and valves are widely used in various industries. We provide quality products and services with international standard for many well know and outstanding companies worldwide. Choose PASCAL, we will provide you with comprehensive products and professional services.



Contents

1

About PASCAL

- ▶ **Company Profile** 01-02
- ▶ **Certifications** 03
- ▶ **Capabilities** 04
- ▶ **Application Areas** 05-06

2

Product Introduction

- ▶ **INTRODUCTION** 07-10
- ▶ **AHP03 Series** 11-12
Single Drive Single Acting
- ▶ **AHP03M Series** 13-14
Single Drive Single Acting
- ▶ **AHP03M Series** 15-16
Single Drive Double Acting
- ▶ **AHP04 Series** 17-18
Single Drive Single Acting
- ▶ **AHP05 Series** 19-20
Single Drive Single Acting
- ▶ **AHP05 Series** 21-22
Single Drive Double Acting
- ▶ **AHP06 Series** 23-24
Single Drive Single Acting
- ▶ **AHP06 Series** 25-26
Double Drive single Acting
- ▶ **AHP06 Series** 27-28
Triple Drive Single Acting
- ▶ **AHP06 Series** 29-30
Single Drive Double Acting
- ▶ **AHP06 Series** 31-32
Double Drive Double Acting
- ▶ **AHP06 Series** 33-34
Long Stroke Single Drive Double Acting
- ▶ **AHP10 Series** 35-36
Single Drive Double Acting
- ▶ **AHP10 Series** 37-38
Double Drive Double Acting
- ▶ **ALG Series** 39-40
Liquefied Gas Pump

► About PASCAL

PASCAL specializes in the R&D, design, and manufacture of high-quality fluid control components, including stainless steel instrumentation valves, high-pressure valves, control valves, high-pressure pumps, and boosters. All our products are built to international standards.

Our 54-acre facility houses 20,000 square meters of modern workshops and office buildings. We are empowered by a seasoned engineering team with over 20 years of expertise, supported by advanced testing and manufacturing equipment, and driven by a comprehensive quality control system. This robust infrastructure, combined with our customer-oriented and professional sales team, enables us to deliver superior services and reliable solutions to the global fluid control industry. PASCAL is certified under the ISO 9001 quality management system, with our products also holding SIL and EAC certifications. Recognized by clients across the Middle East, European Union, Russia, China, and numerous other countries, our products are trusted worldwide.

Through years of dedication, PASCAL has emerged as an industry leader, cultivating a growing list of regular customers from around the globe. Our solutions are widely used in a diverse range of industries, including oil & gas, petrochemical, energy, mining, aerospace, automotive, fire-fighting, and conventional hydraulic machinery.

Committed to high-end ultra-high and high pressure pump, booster and valve internationalization

Become the global leader in fluid control industry

Because focus So professional

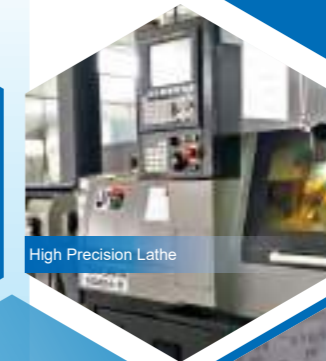

High Precision Lathe



Warehouse



Three Coordinate Measuring Machine



Product Test Chamber

Manufacturing Capability

Production Scale and Equipment:

- 1, The complex spans 8.9 acres (54 mu), with a 2,000-square-meter office building and an assembly workshop reaching 6,000 square meters in area.
- 2, Equipped with over 70 high-end imported machines, including CNC machine tools, multi-tasking machines, multi-axis machining centers, Swiss-type lathes, and precision internal honing machines.
- 3, Features a comprehensive array of testing equipment such as optical inspection systems, spectrometers, surface roughness testers, hardness testers, spring testing machines, universal material testing machines, hydrostatic pressure testers, airtightness testers, and helium mass spectrometers.

► Certifications & Honors

-
- Certified to ISO 9001-2015 Quality Management System Standard
- Products Certified with CE, ATEX, SIL, and EAC International Standards
- National High-Tech Enterprise (Certificate No.: Gr202242000099)
-
-



Technical Expertise

R&D Team

The company's R&D team consists of senior engineers with over 20 years of experience in fluid control. Additionally, the company operates a technical R&D center in Wuhan, attracting top technical talent.

Patent Portfolio

As of January 2025, the company holds 36 invention and utility model patents spanning fluid control, advanced manufacturing processes, and related fields.

Core Technologies

- 1, Proprietary Ultra-High-Pressure Sealing Technology – Long lifespan and cost-effectiveness.
- 2, Specialized Material Treatment Processes – High-pressure resistance with guaranteed safety.
- 3, Innovative Pump & Valve Structural Designs – Easy maintenance and user-friendly operation.

Accreditations & Certifications

The company has been recognized with prestigious certifications, including National High-Tech Enterprise, Shandong Provincial "Specialized, Refined, Distinctive, and Innovative" Enterprise, and Hubei Provincial Hidden Champion Enterprise (awarded to niche market leaders). Its R&D efforts remain focused on ultra-high-pressure systems, corrosion-resistant materials, and intelligent control technologies. Products comply with ATEX Explosion-Proof Certification and SIL Functional Safety Certification, meeting stringent industrial requirements.



VMC



A corner of workshop

► Application Industries (Typical)



Descriptions of the boosters

► Features

- The pump's maximum output pressure can reach **100,000 psi (700 Mpa)**.
- The pump's cycling speed allows infinitely variable adjustment.
- When the output pressure reaches the preset value, the pump maintains constant pressure without energy consumption.
- Easy to automate, with multiple optional control configurations.
- Compatible with most liquids and liquefied gases.
- CE-certified, compliant with ATEX and NACE standards.
- Compact design, high reliability, and low maintenance requirements.
- Customizable pumps for specialized applications upon request.
- Air-driven section operates without pipeline lubrication, reducing costs and preventing contamination.
- Supports multiple drive gases (air, nitrogen, CO₂, natural gas).
- Suitable for most liquids and liquefied gases.

► Basic Simple Principles and Operating Procedures

Pre-Pressurization Preparation:

Prepare a Manually Operated Pump:

- Connect pipelines (drive gas source pipeline, liquid medium input pipeline, and high-pressure output pipeline).
- Open the drive gas source switch and slowly adjust the drive gas pressure to start the pump.
- Set the drive gas pressure.

Pressurization Process:

Pump Pressurization Process:

- When the drive piston moves away from the pump head, the outlet check valve closes, and the inlet check valve opens to draw liquid into the pump.
- Fluid is sucked into the pump head.
- When the piston reaches the bottom of the rear end, it triggers the cycle valve to reverse.
- After the cycle valve reverses, the piston moves toward the other end, compressing the fluid in the pump head.
- The inlet check valve closes, and the outlet check valve opens to discharge the fluid.
- When the piston reaches the bottom of the front end, it triggers the cycle valve to reverse again.
- The reciprocating motion of the piston continuously discharges fluid to the pump outlet, achieving rear-end pressurization.

Reaching Pressure and Pressure Retention:

Process of Achieving Output Pressure and Maintaining Pressure:

- The pump stops operating when the output pressure balances with the drive gas pressure according to the output ratio.
- The pump maintains the output pressure without action, consuming no gas and generating no heat.
- If the outlet pressure drops, the pump automatically restarts.

Operating Condition Requirements:

PASCAL recommends adhering to the ISO8573.1 standard, with a minimum requirement of Class 4 driving air quality. In extremely low-temperature operating conditions,

► Applications

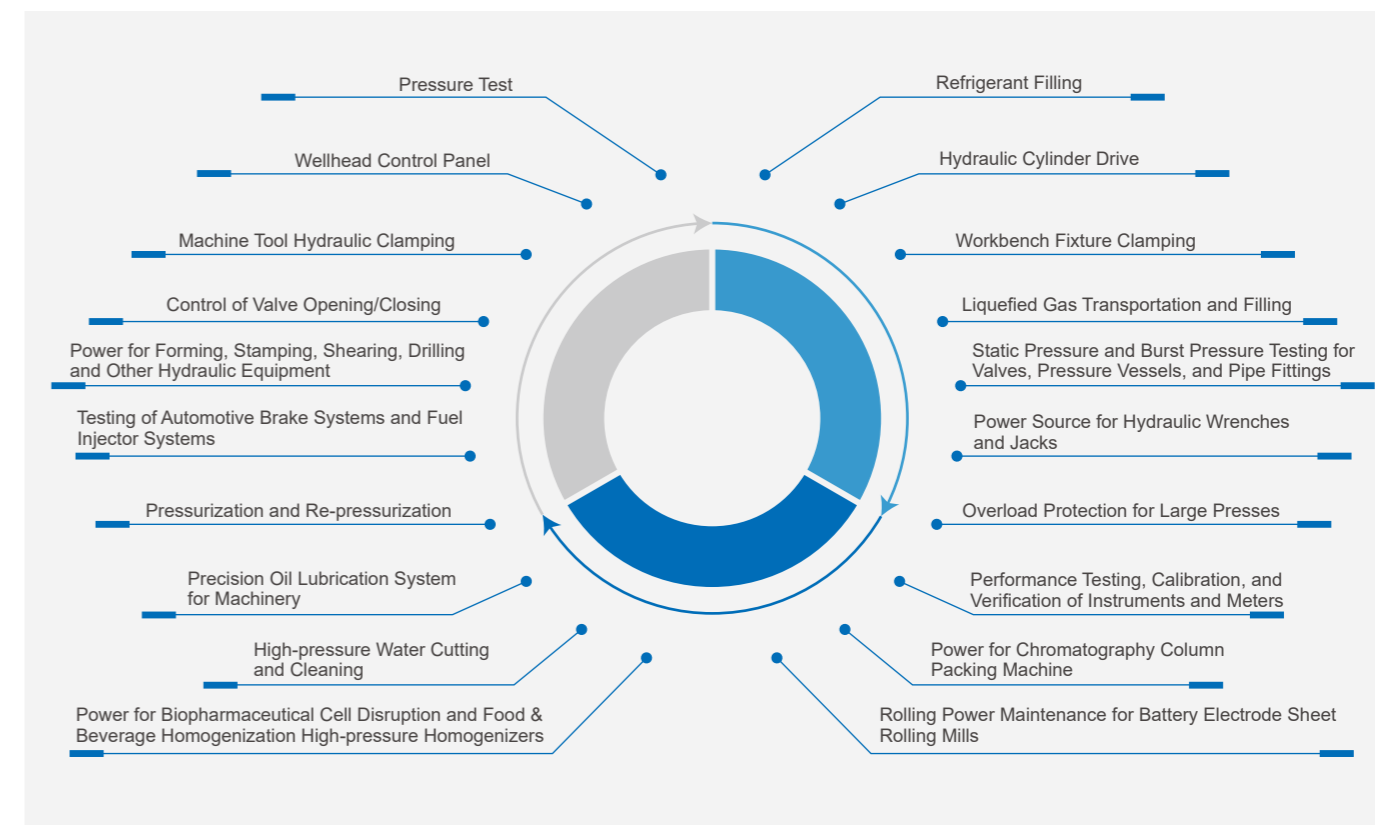

► Model Code Explanation

- All model codes listed in the legends later in this manual are standard models.
 - For pumps with handle add “-H” after the model codes (applicable only to 3” single drive single acting pumps).
 - For pumps requiring isolation, add “-D” after the model.
- For pumps add “-V” after the model codes (Viton seals must be used).
- Special Interface Requirement: Add “-X” after the model (air-driven section equipped with an external pilot interface).

Custom Service Instructions:

Other sizes, materials, and types of pumps can be provided according to customer requirements. If there are special requirements, [please contact us](#).

Model Selection Guide:

Select the pump model based on your application requirements, such as output pressure, output flow rate, operating medium and temperature, available compressed air source or air drive pressure and flow rate. This selection guide will assist you in choosing the pump that best suits your needs.

If you have any questions, [please contact us](#). Based on the compressed air source or air drive pressure you can provide, we will recommend pumps and corresponding accessories that meet your required flow rate and pressure.

Descriptions of the boosters

► Types and Functions of the boosters

Working Principle:
 PASCAL pumps offer the right solution for every application. They are suitable for different or stepped flow rates as well as for different maximum allowable operating pressures.

Pump Type Characteristics

Multi - drive Pump

- Double - drive: Pressure increase ratio X2
- Triple - drive: Pressure increase ratio X3

Double - acting Pump

- Fluid can be output in both reciprocating strokes, improving output power.

Manual Emergency Pump

- The pump with a handle can use manual pressurization when there is no driving air pressure.

► Structure of Hydraulic Pump Interface Configuration

Interface Configuration

• Standard type: Inlet and outlet are in the same straight line.	• Angular Pumps Angle - type pump: Inlet and outlet are distributed at 90°.
--	---

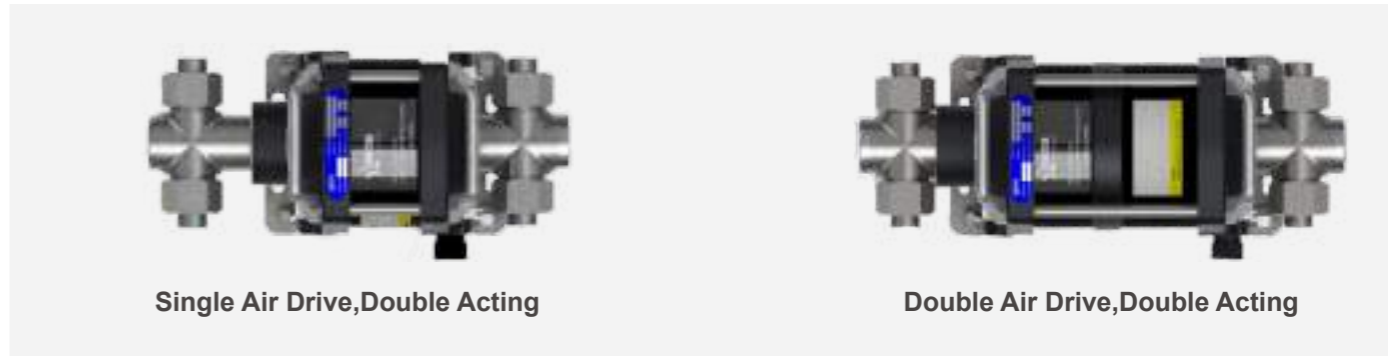
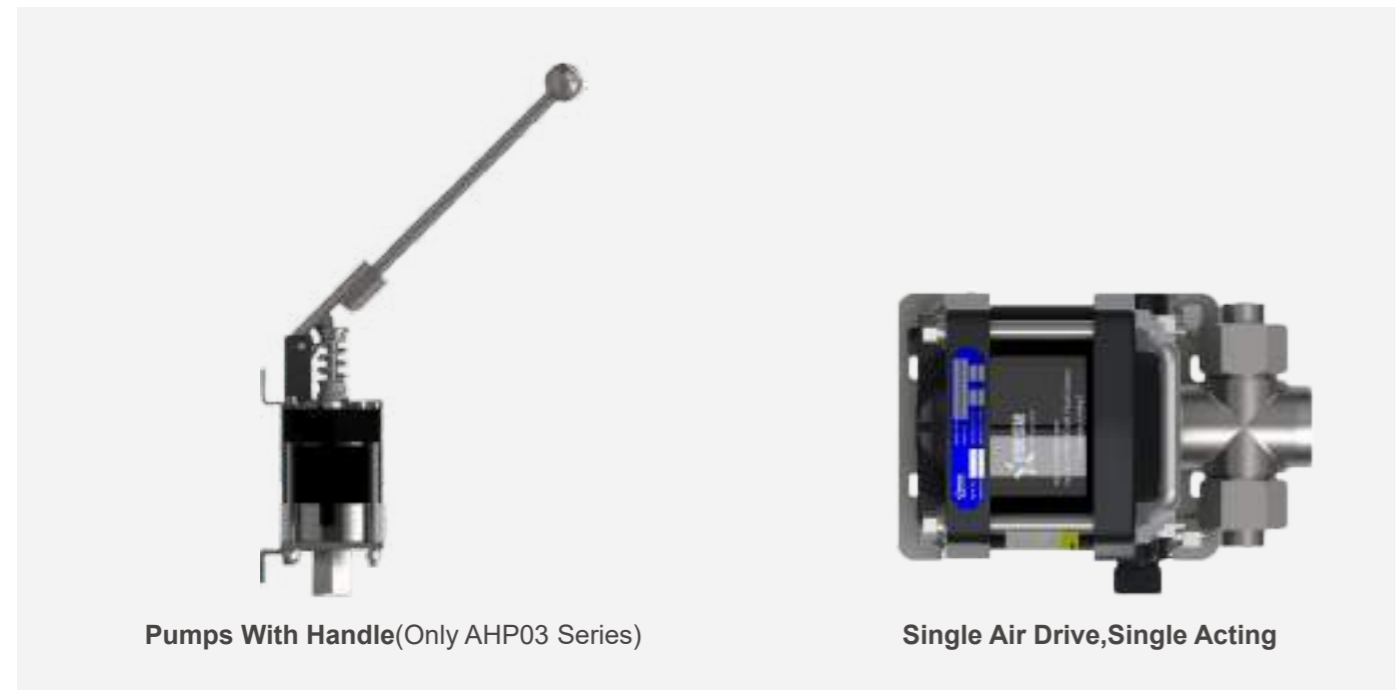

AHP03 Series ▶ Single Drive Single Acting

▶ Features

- Choice of 9 ratios.
- Flows to 8.3 L/min.
- Choice of wetted materials.
- Pressures to 25,000 psi(1723 bar).
- All Hydraulic fluids, water(plain or DI), solvents, mild chemicals, liquefied gases.



▶ Performance and Specification

Pump Model code	Max.Out Press	Actual Ratio	Dis./Cycle	Max.Flow	Inlet Port	Outlet Port	Air Drive Port
AHP03-1S-5	625psi(4.3MPa)	5.6:1	13.6mL	8.30L/min	3/4"FNPT	1/2"FNPT	1/4"FNPT
AHP03-1S-7	900psi(6.2MPa)	7.8:1	9.8mL	6.0L/min	3/4"FNPT	1/2"FNPT	1/4"FNPT
AHP03-1S-12	1500psi(10.3MPa)	14:1	5.9mL	3.83L/min	3/8"FNPT	1/4"FNPT	1/4"FNPT
AHP03-1S-21	2600psi(17.9MPa)	25:1	3.3mL	2.13L/min	3/8"FNPT	1/4"FNPT	1/4"FNPT
AHP03-1S-36	4500psi(31MPa)	41:1	2.0mL	1.28L/min	3/8"FNPT	1/4"FNPT	1/4"FNPT
AHP03-1S-71	8800psi(60.7MPa)	82:1	1.0mL	0.64L/min	3/8"FNPT	1/4"FNPT	1/4"FNPT
AHP03-1S-110	13500psi(93.1MPa)	126:1	0.6mL	0.42L/min	3/8"FNPT	1/4"FNPT	1/4"FNPT
AHP03-1S-188	15000psi(103.4MPa)	217:1	0.4mL	0.29L/min	3/8"FNPT	1/4"HF	1/4"FNPT
AHP03-1S-220	25000psi(172.4MPa)	237:1	0.34mL	0.22L/min	3/8"FNPT	1/4"HF	1/4"FNPT

"HF" means female high pressure connection, The max outlet pressure is based on the air drive pressure at 110psi (0.76MPa); The max flow rate is based on outlet pressure at 0 psi (working empty) .

▶ Dimensions

in.(mm)

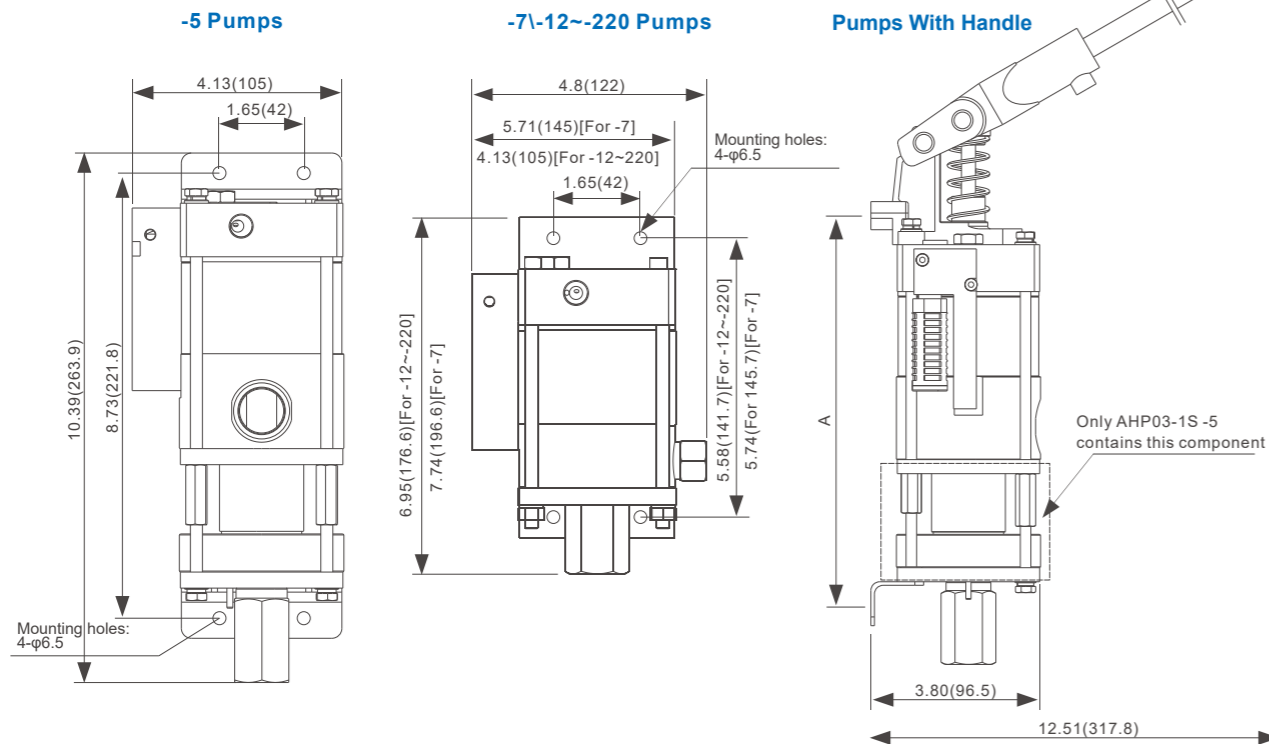

Remarks: For AHP03-1S-5, A = 8.73x1.65(221.8x42); For AHP03-1S-7, A = 5.74x1.65(145.7x42); For other pumps, A = 5.58x1.65(141.7x42).



▶ Performance Curves

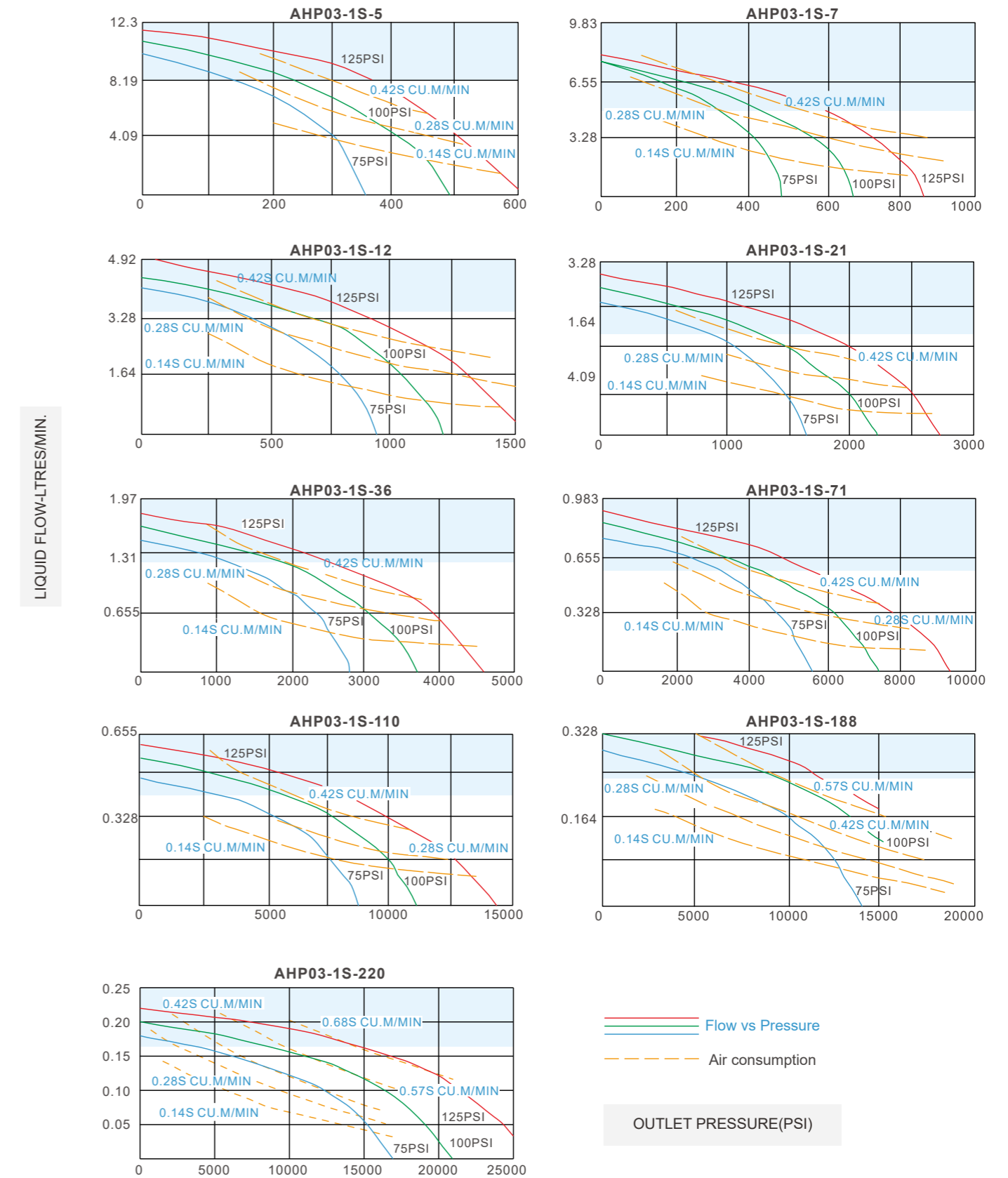

Note: The shaded area in the diagram indicates excessive circulation rate or pressure. Use intermittently.

AHP03M Series ▶ Single Drive Single Acting



▶ Features

- Choice of 8 ratios.
- Flows to 14.81 L/min.
- Choice of wetted materials.
- Pressures to 31,900 psi(2199 bar).
- All Hydraulic fluids, water(plain or DI), solvents, mild chemicals, liquefied gases.



▶ Performance and Specification

Pump Model code	Max.Out Press	Actual Ratio	Dis./Cycle	Max.Flow	Inlet Port	Outlet Port	Air Drive Port
AHP03M-1S-4	580psi(4MPa)	4:1	30.5mL	14.81L/min	G 1"	G 1/2"	G 3/8"
AHP03M-1S-8	1305psi(9MPa)	9:1	14.7mL	7.07L/min	G 3/4"	G 1/2"	G 3/8"
AHP03M-1S-12	2030psi(14MPa)	14:1	9.4mL	4.55L/min	G 3/4"	G 1/2"	G 3/8"
AHP03M-1S-22	4060psi(28MPa)	28:1	4.6mL	2.22L/min	G 3/8"	G 3/8"	G 3/8"
AHP03M-1S-37	6670psi(46MPa)	46:1	2.8mL	1.36L/min	G 3/8"	G 3/8"	G 3/8"
AHP03M-1S-72	12470psi(86MPa)	86:1	1.5mL	0.72L/min	G 3/8"	G 3/8"	G 3/8"
AHP03M-1S-111	18850psi(130MPa)	130:1	1.0mL	0.48L/min	G 3/8"	G 3/8"	G 3/8"
AHP03M-1S-189	31900psi(220MPa)	220:1	0.6mL	0.28L/min	G 3/8"	G 3/8"	G 3/8"

The max outlet pressure is based on the air drive pressure at 145psi(1MPa); The max flow rate is based on outlet pressure at 0 psi (working empty) .

▶ Dimensions

in.(mm)

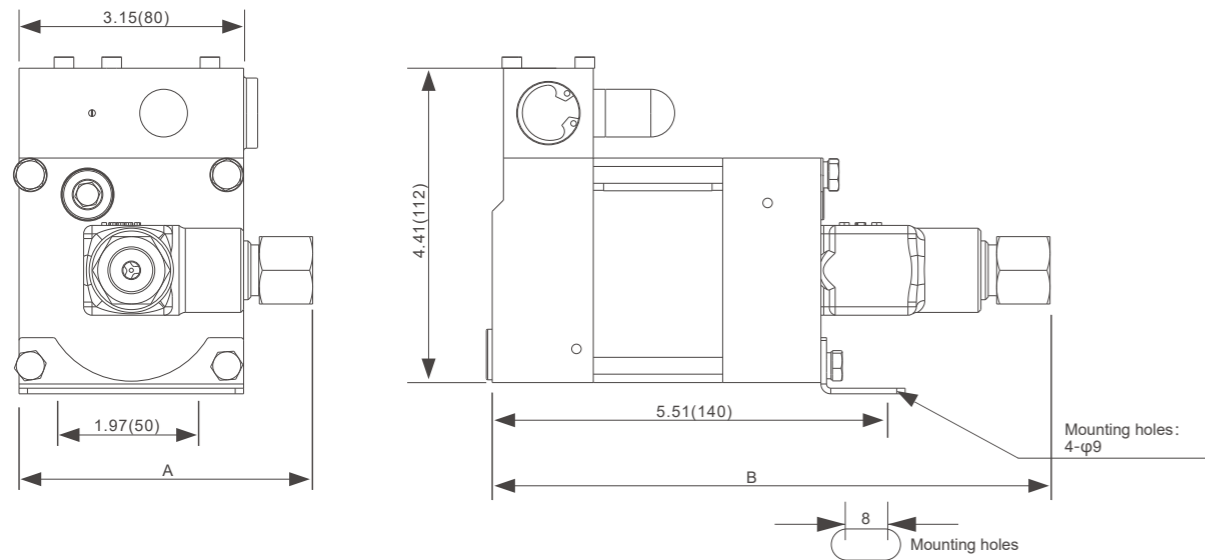

▶ Performance Curves

Air consumption(LN/min)

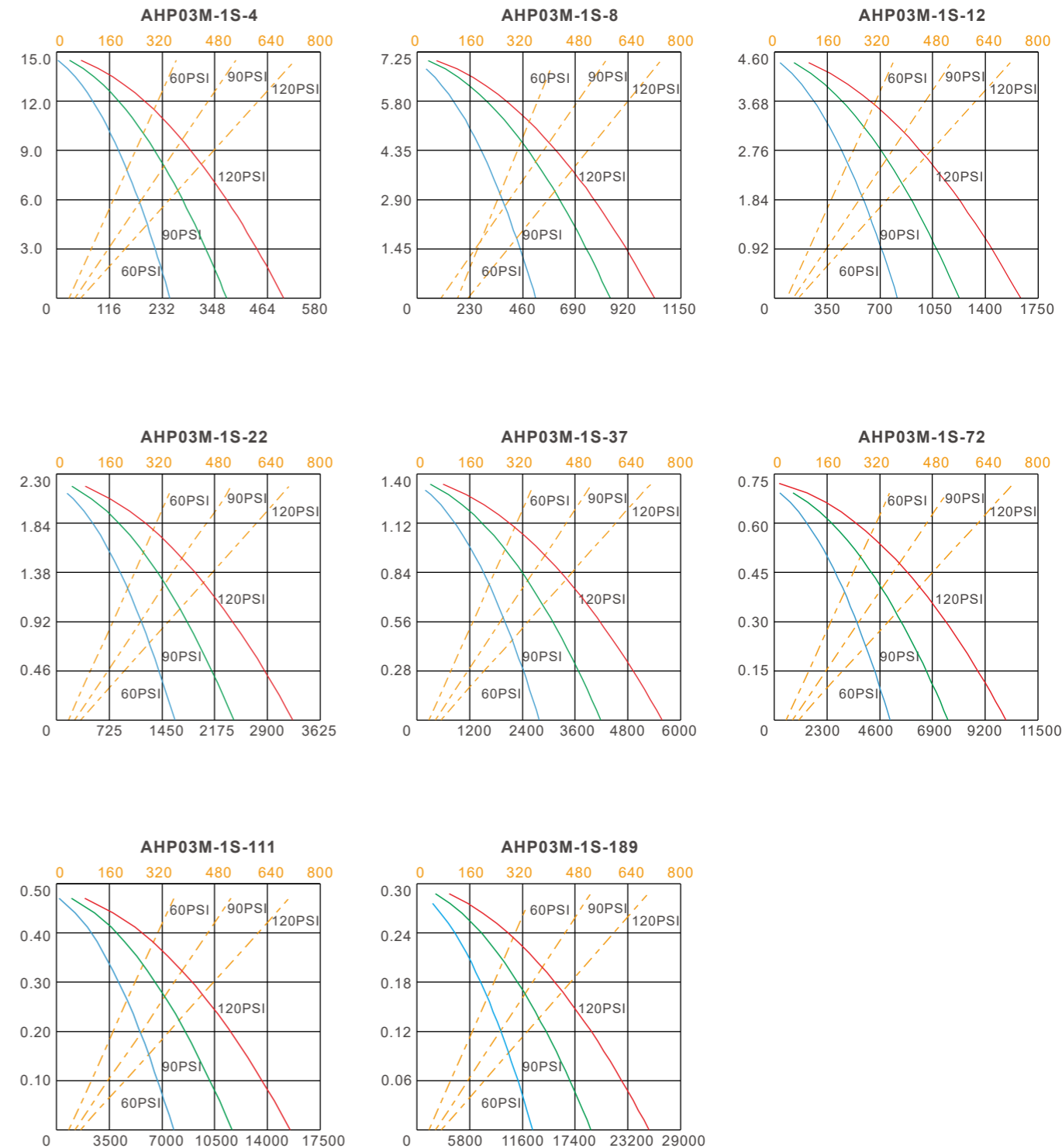

OUTLET PRESSURE(PSI)

— Flow vs Pressure
- - - Air consumption

Remarks: For AHP03M-1S-4\8\12,A =4.72(120); For AHP03M-1S-22\37\72\111\189,A=4.09(104);

For AHP03M-1S-4,B =8.50(216); For AHP03M-1S-8\12,B=8.23(209); For AHP03M-1S-22\37\72\111\189,B =7.68(195).

Note: The shaded area in the diagram indicates excessive circulation rate or pressure. Use intermittently.

AHP03M Series ▶ Single Drive Double Acting

▶ Features

- Choice of 8 ratios.
- Flows to 25 L/min.
- Choice of wetted materials.
- Pressures to 31,900 psi(2199 bar).
- All Hydraulic fluids, water(plain or DI), solvents, mild chemicals, liquefied gase.



▶ Performance and Specification

Pump Model code	Max.Out Press	Actual Ratio Dis./Cycle	Max.Flow	Inlet Port	Outlet Port	Air Drive Port	
AHP03M-1D-4	440psi(3MPa)	3:1	61mL	25L/min	G 1"	G 1/2"	G 3/8"
AHP03M-1D-8	1160psi(8MPa)	8:1	29.4mL	12L/min	G 3/4"	G 1/2"	G 3/8"
AHP03M-1D-12	1890psi(13MPa)	13:1	18.3mL	7.8L/min	G 3/4"	G 1/2"	G 3/8"
AHP03M-1D-22	4060psi(28MPa)	28:1	9.2mL	3.91L/min	G 3/8"	G 3/8"	G 3/8"
AHP03M-1D-37	6670psi(46MPa)	46:1	5.6mL	2.35L/min	G 3/8"	G 3/8"	G 3/8"
AHP03M-1D-72	12470psi(86MPa)	86:1	3.0mL	1.24L/min	G 3/8"	G 3/8"	G 3/8"
AHP03M-1D-111	18850psi(130MPa)	130:1	2.0mL	0.82L/min	G 3/8"	G 3/8"	G 3/8"
AHP03M-1D-189	31900psi(220MPa)	220:1	1.2mL	0.49L/min	G 3/8"	G 3/8"	G 3/8"

The max outlet pressure is based on the air drive pressure at 145psi(1MPa); The max flow rate is based on outlet pressure at 0 psi (working empty) .

▶ Dimensions

in.(mm)

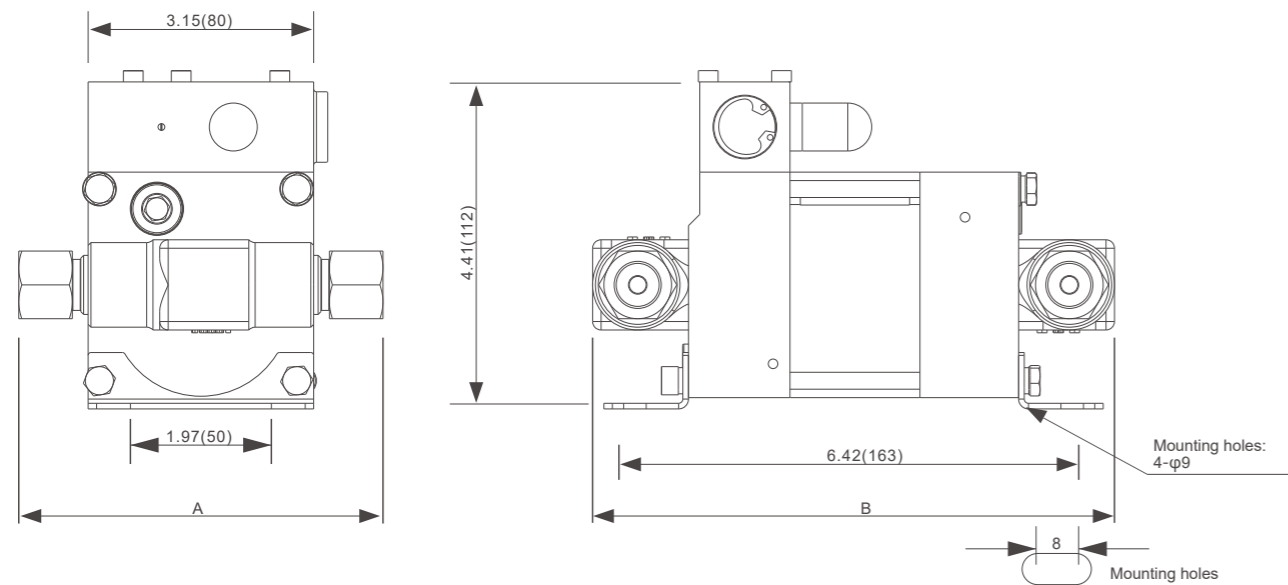

Remarks: For AHP03M-1D-4\8\12,A=4.69(119); For AHP03M-1D-22\37\72\111\189,A=5.08(129);

For AHP03M-1S-4,B=12.36(314); For AHP03M-1S-8\12,B=11.81(300); For AHP03M-1S-22\37\72\111\189,B=7.28(185).

▶ Performance Curves

Air consumption(LN/min)

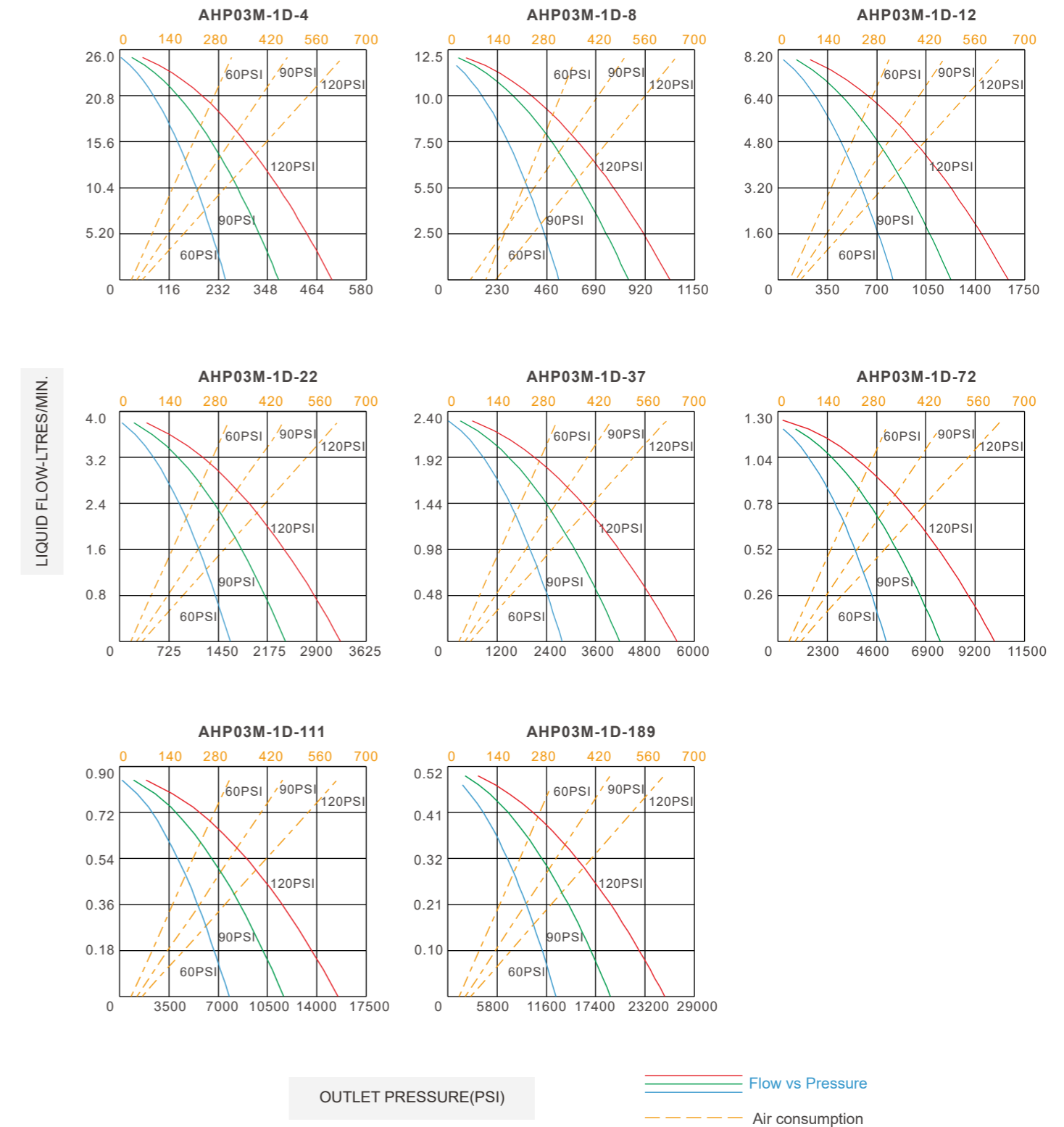

LIQUID FLOW-LITRES/MIN.

OUTLET PRESSURE(PSI)

Note: The shaded area in the diagram indicates excessive circulation rate or pressure. Use intermittently.

AHP04 Series ▶ Single Drive Single Acting

▶ Features

- Choice of 9 ratios.
- Flows to 7.01 L/min.
- Choice of wetted materials.
- Pressures to 15000 psi(1034bar).
- All Hydraulic fluids, water(plain or DI), solvents, mild chemicals, liquefied gases.



▶ Performance and Specification

Pump Model code	Max.Out Press	Actual Ratio	Dis./Cycle	Max.Flow	Inlet Port	Outlet Port	Air Drive Port
AHP04-1S-14	1500psi(10.3MPa)	16:1	14.7mL	7.01L/min	3/4"FNPT	1/2"FNPT	1/2"FNPT
AHP04-1S-21	2300psi(15.9MPa)	24:1	9.8mL	4.67L/min	3/4"FNPT	1/2"FNPT	1/2"FNPT
AHP04-1S-25	2700psi(18.6MPa)	29:1	8.2mL	3.89L/min	3/4"FNPT	1/2"FNPT	1/2"FNPT
AHP04-1S-30	3200psi(22.1MPa)	34:1	7.0mL	3.35L/min	3/4"FNPT	1/2"FNPT	1/2"FNPT
AHP04-1S-37	3800psi(26.2MPa)	42:1	5.7mL	2.72L/min	3/4"FNPT	1/2"FNPT	1/2"FNPT
AHP04-1S-55	6000psi(41.4MPa)	63:1	3.6mL	1.71L/min	1/2"FNPT	1/4"FNPT	1/2"FNPT
AHP04-1S-75	7800psi(53.8MPa)	86:1	2.8mL	1.32L/min	1/2"FNPT	1/4"FNPT	1/2"FNPT
AHP04-1S-100	10600psi(73.1MPa)	114:1	2.0mL	1.01L/min	1/2"FNPT	1/4"FNPT	1/2"FNPT
AHP04-1S-150	15000psi(103.4MPa)	171:1	1.44mL	0.68L/min	1/2"FNPT	1/4"FNPT	1/2"FNPT

The max outlet pressure is based on the air drive pressure at 110psi(0.76MPa); The max flow rate is based on outlet pressure at 0 psi (working empty) .

▶ Dimensions

in.(mm)

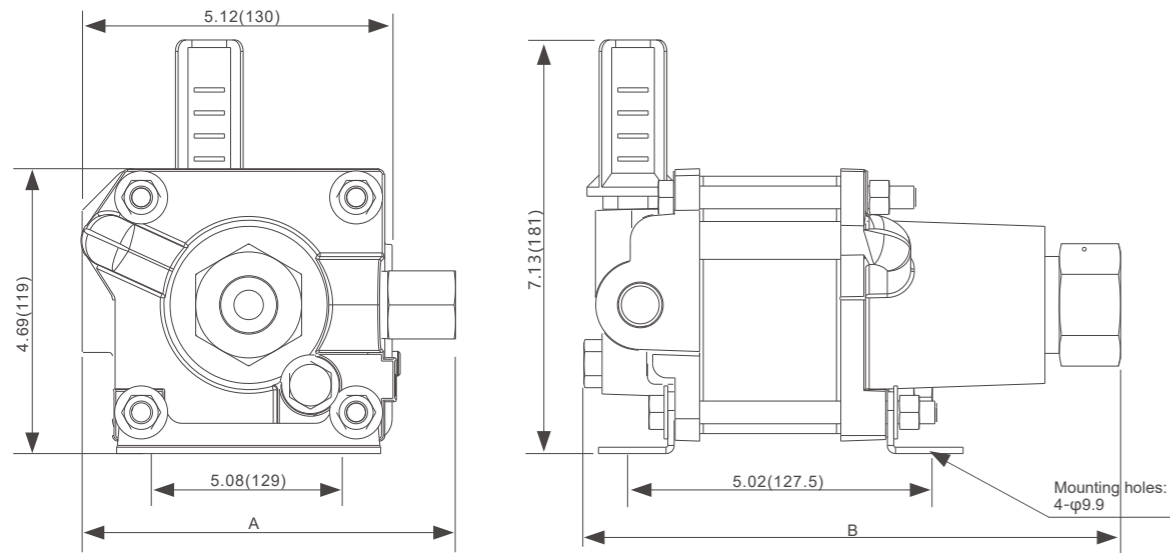

Remarks: For AHP04-1S-14\21\25\30\37,A =6.18(157); For AHP04-1S-55\75\100\150,A=4.33(110);
For AHP04-1S-14\21\25\30\37,B =8.86(225); For AHP04-1S-55\75\100\150,B=8.50(216).

▶ Performance Curves

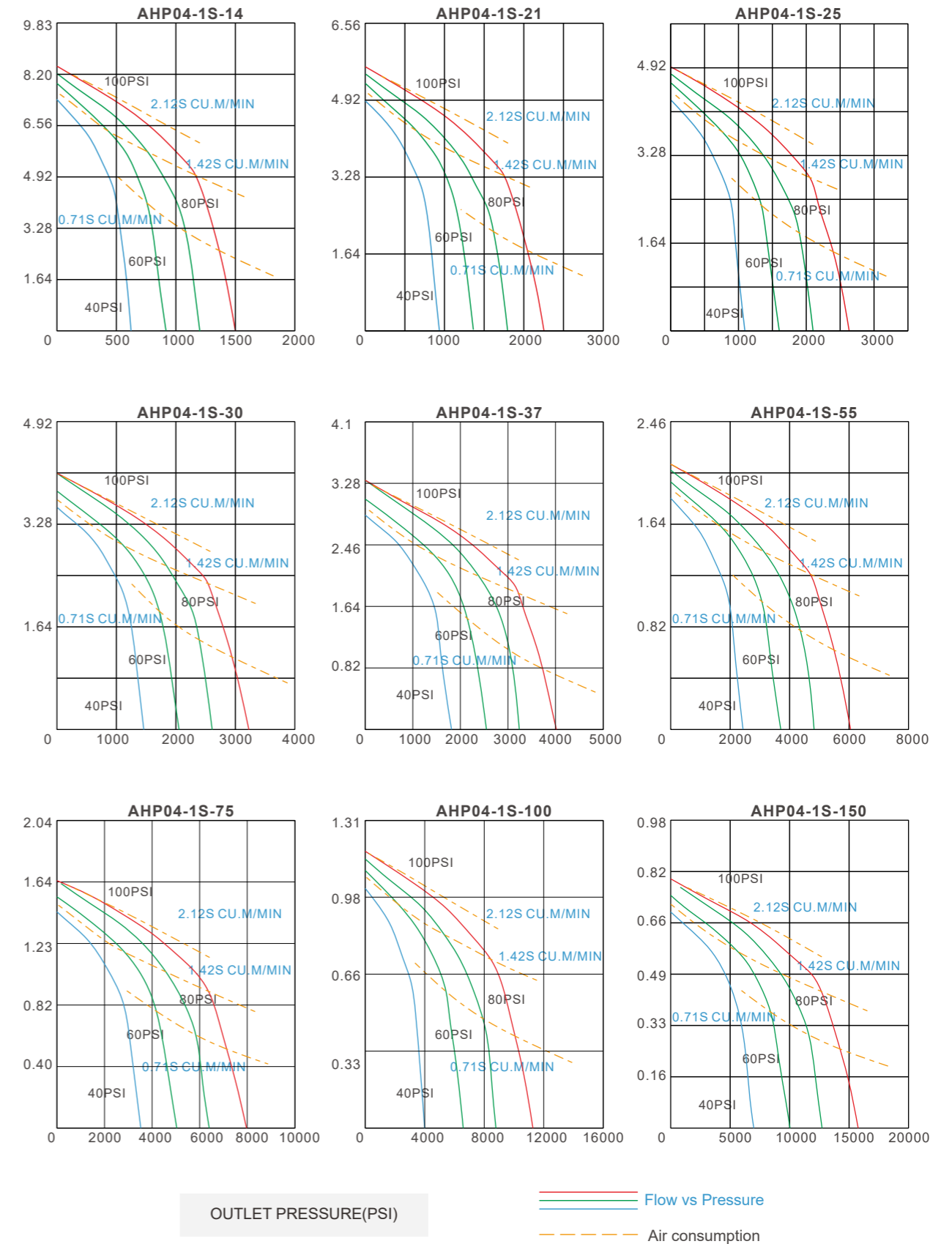

LIQUID FLOW-LITRES/MIN.

OUTLET PRESSURE(PSI)

— Flow vs Pressure
- - - Air consumption

Note: The shaded area in the diagram indicates excessive circulation rate or pressure. Use intermittently.

AHP05 Series ▶ Single Drive Single Acting



▶ Features

- Choice of 6 ratios.
- Flows to 9.38 L/min.
- Choice of wetted materials.
- Pressures to 14,500 psi(1000 bar).
- All Hydraulic fluids, hydraulic, emulsion,etc.



▶ Performance and Specification

Pump Model code	Max.Out Press	Actual Ratio	Dis./Cycle	Max.Flow	Inlet Port	Outlet Port	Air Drive Port
AHP05-1S-15	2465psi(17MPa)	17:1	28.3mL	9.38L/min	G 3/4"	G 3/4"	G 1/2"
AHP05-1S-25	3625psi(25MPa)	25:1	19.6mL	6.72L/min	G 3/4"	G 3/4"	G 1/2"
AHP05-1S-35	5655psi(39MPa)	39:1	12.6mL	4.31L/min	G 3/4"	G 3/4"	G 1/2"
AHP05-1S-60	8845psi(61MPa)	61:1	8.0mL	2.75L/min	G 1/2"	G 3/8"	G 1/2"
AHP05-1S-100	14500psi(100MPa)	108:1	4.5mL	1.55L/min	G 1/2"	G 3/8"	G 1/2"
AHP05-1S-150	14500psi(100MPa)	156:1	3.1mL	1.08L/min	G 1/2"	G 3/8"	G 1/2"

The max outlet pressure is based on the air drive pressure at 145psi(1MPa); The max flow rate is based on outlet pressure at 0 psi (working empty) .

▶ Dimensions

in.(mm)

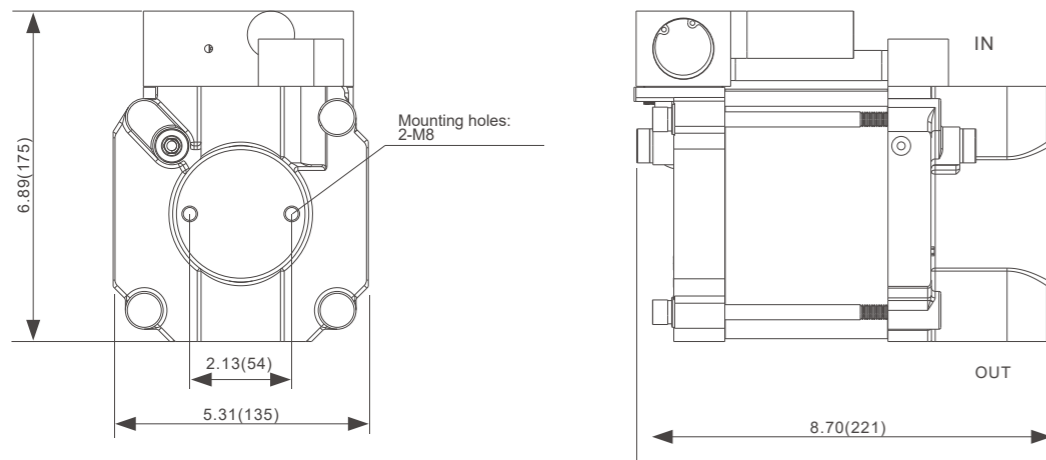

▶ Performance Curves

Air consumption(LN/min)

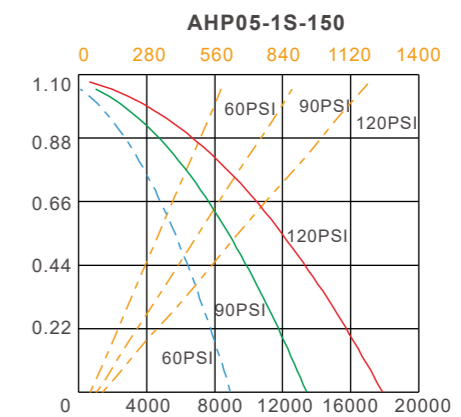
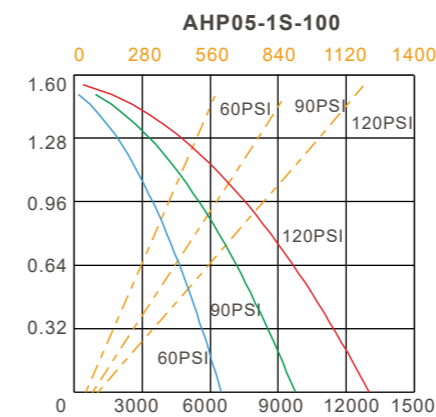
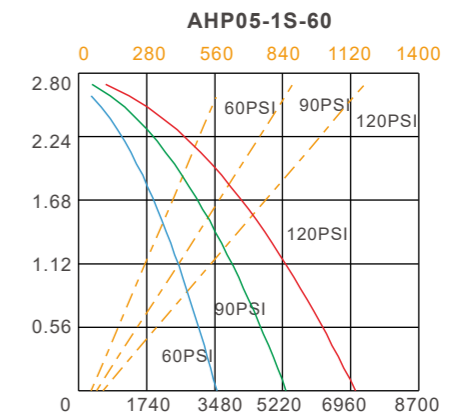
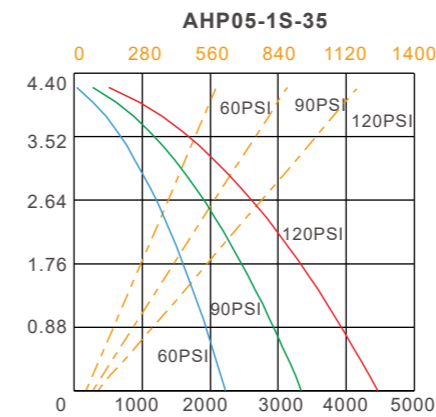
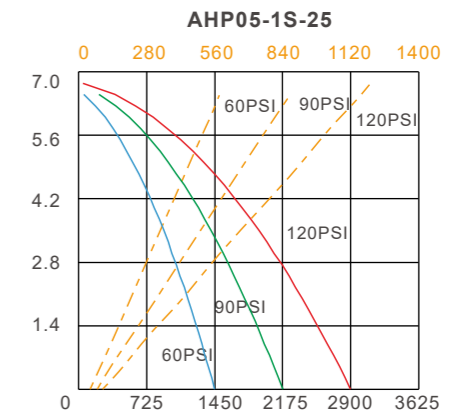
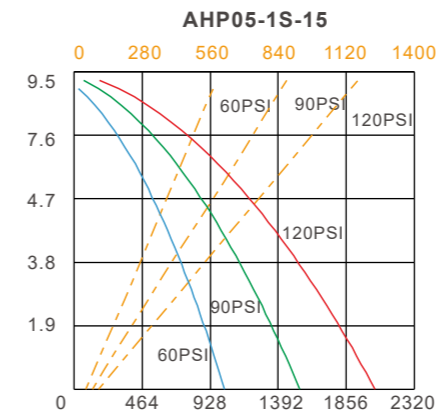

LIQUID FLOW-LITRES/MIN.

OUTLET PRESSURE(PSI)

— Flow vs Pressure
 - - - Air consumption

AHP05 Series ▶ Single Drive Double Acting

▶ Features

- Choice of 6 ratios.
- Flows to 17.5 L/min.
- Choice of wetted materials.
- Pressures to 14,500 psi(1000 bar).
- All Hydraulic fluids, hydraulic, emulsion, etc.



▶ Performance and Specification

Pump Model code	Max.Out Press	Actual Ratio	Dis./Cycle	Max.Flow	Inlet Port	Outlet Port	Air Drive Port
AHP05-1D-15	2320psi(16MPa)	16:1	57mL	17.5L/min	G 3/4"	G 3/4"	G 1/2"
AHP05-1D-25	3480psi(24MPa)	24:1	39mL	12L/min	G 3/4"	G 3/4"	G 1/2"
AHP05-1D-35	5510psi(38MPa)	38:1	25.2mL	7.58L/min	G 3/4"	G 3/4"	G 1/2"
AHP05-1D-60	8700psi(60MPa)	60:1	16mL	4.8L/min	G 1/2"	G 3/8"	G 1/2"
AHP05-1D-100	14500psi(100MPa)	107:1	9mL	2.68L/min	G 1/2"	G 3/8"	G 1/2"
AHP05-1D-150	14500psi(100MPa)	155:1	6.2mL	1.85L/min	G 1/2"	G 3/8"	G 1/2"

The max outlet pressure is based on the air drive pressure at 145psi(1MPa); The max flow rate is based on outlet pressure at 0 psi (working empty) .

▶ Dimensions

in.(mm)

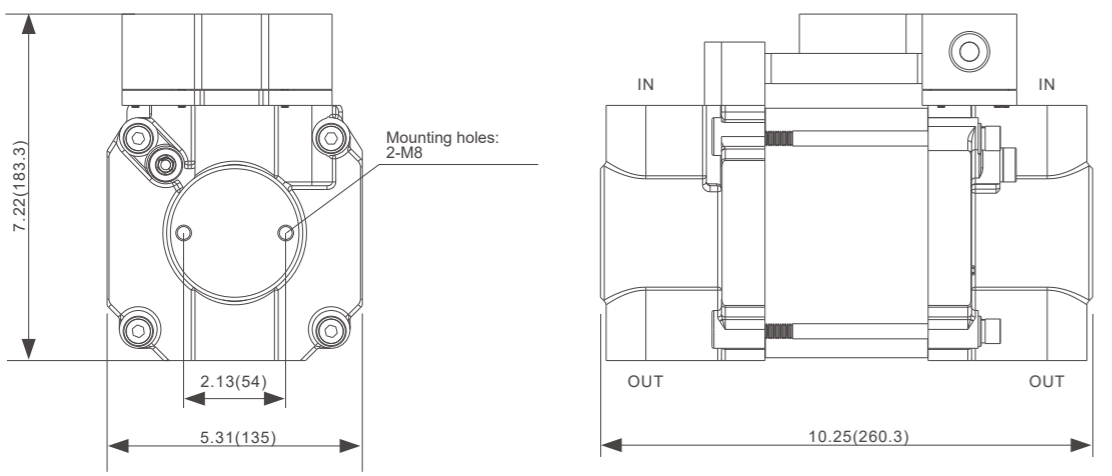

▶ Performance Curves

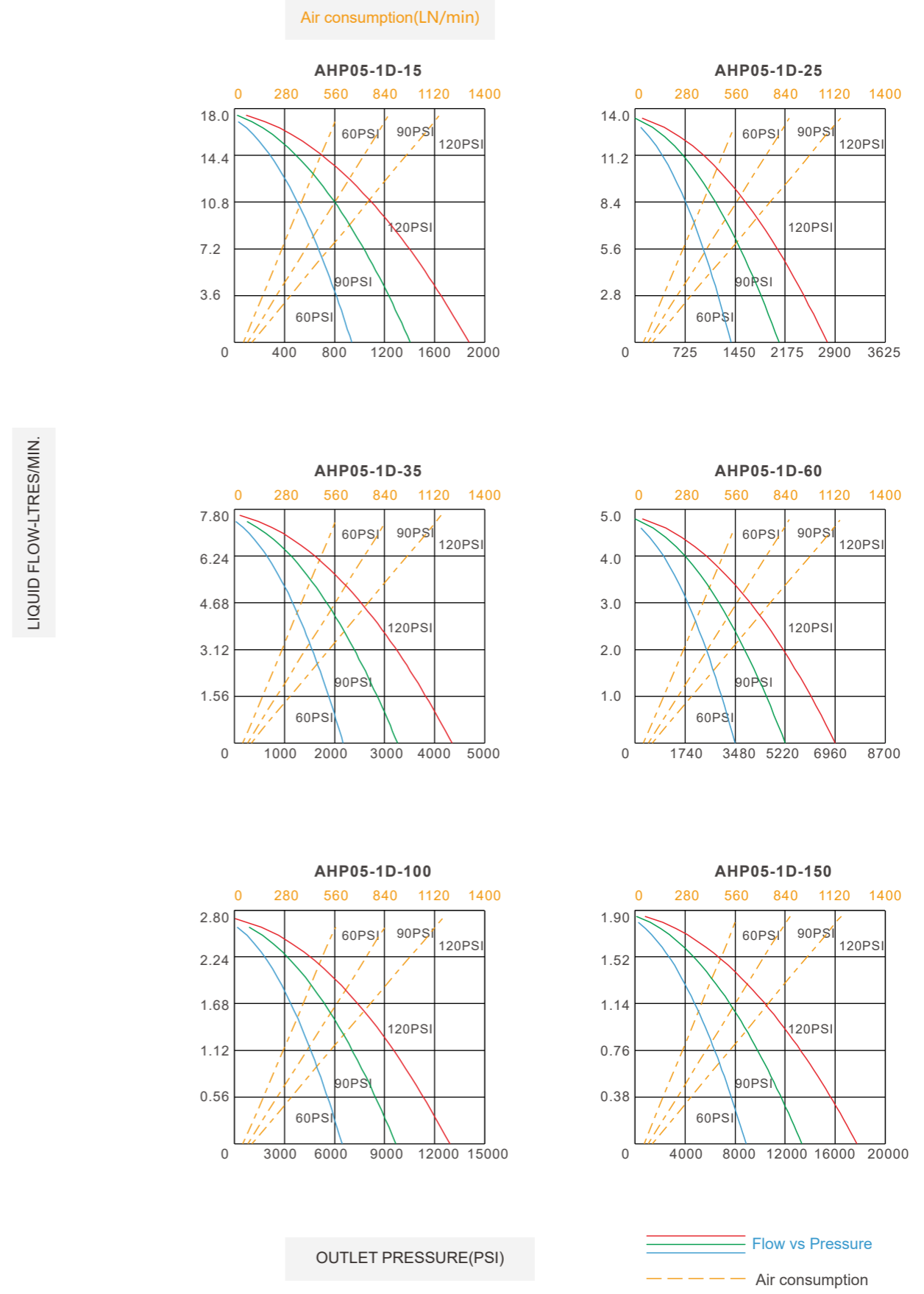

AHP06 Series ▶ Single Drive Single Acting

▶ Features

- Choice of 10 ratios.
- Flows to 19.9 L/min.
- Choice of wetted materials.
- Pressures to 60,000 psi(4137 bar).
- Drive pressure 30 to 150 psi (2 to 10.3 bar).
- All Hydraulic fluids, water(plain or DI), solvents, mild chemicals, liquefied gases.



▶ Performance and Specification

Pump Model code	Max.Out Press	Actual Ratio	Dis./Cycle	Max.Flow	Inlet Port	Outlet Port	Air Drive Port
AHP06-1S-10	1600psi(11MPa)	14:1	66.4mL	19.9L/min	1"FNPT	1/2"FNPT	3/4"FNPT
AHP06-1S-15	2400psi(16.6MPa)	18:1	44.3mL	13.3L/min	1"FNPT	1/2"FNPT	3/4"FNPT
AHP06-1S-25	4000psi(27.6MPa)	30:1	26.6mL	8.0L/min	1/2"FNPT	1/2"FNPT	3/4"FNPT
AHP06-1S-35	5700psi(39.3MPa)	45:1	19.0mL	5.7L/min	1/2"FNPT	1/2"FNPT	3/4"FNPT
AHP06-1S-60	10000psi(69MPa)	72:1	11.0mL	3.3L/min	1/2"FNPT	1/2"FNPT	3/4"FNPT
AHP06-1S-100	15000psi(103.4MPa)	120:1	6.7mL	2L/min	1/2"FNPT	1/2"FNPT	3/4"FNPT
AHP06-1S-150	22500psi(155.2MPa)	180:1	4.5mL	1.3L/min	1/2"FNPT	3/8"HF	3/4"FNPT
AHP06-1S-225	33750psi(232.8MPa)	270:1	3.0mL	0.7L/min	1/2"FNPT	1/4"HF	3/4"FNPT
AHP06-1S-300	45000psi(310.3MPa)	360:1	2.3mL	0.5L/min	1/2"FNPT	1/4"HF	3/4"FNPT
AHP06-1S-450	60000psi(413.8MPa)	545:1	1.5mL	0.3L/min	1/2"FNPT	1/4"HF	3/4"FNPT

HF means female high pressure connection, The max outlet pressure is based on the air drive pressure at 125psi (0.86MPa); The max flow rate is based on outlet pressure at 0 psi (working empty) .

▶ Dimensions

in.(mm)

AHP06-1S-10~15 Pumps

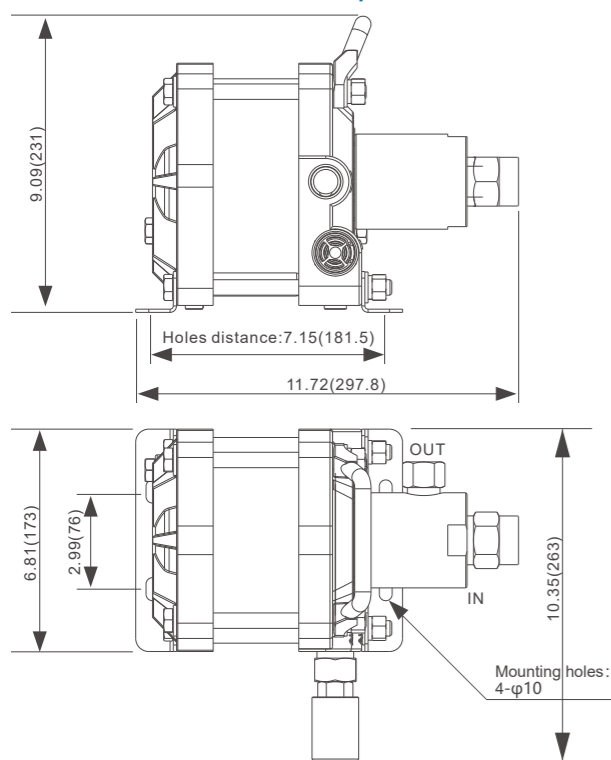

AHP06-1S-25~450 Pumps

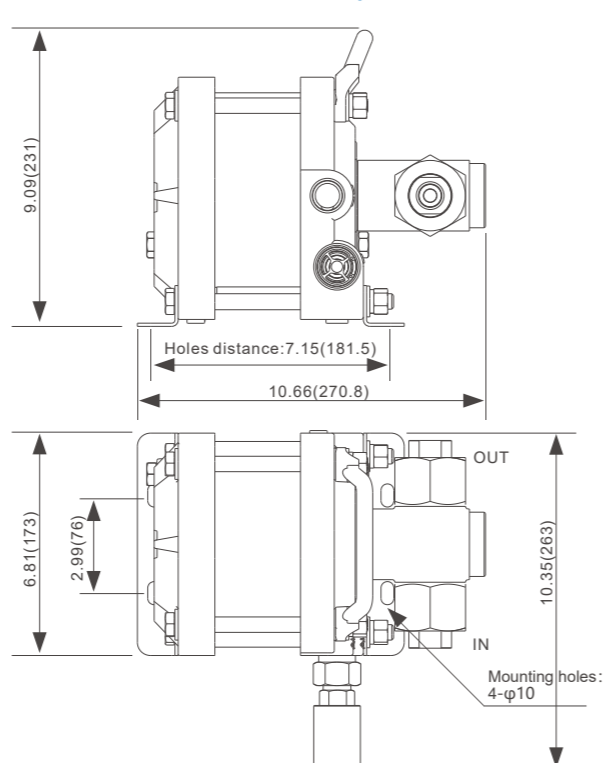

▶ Performance Curves

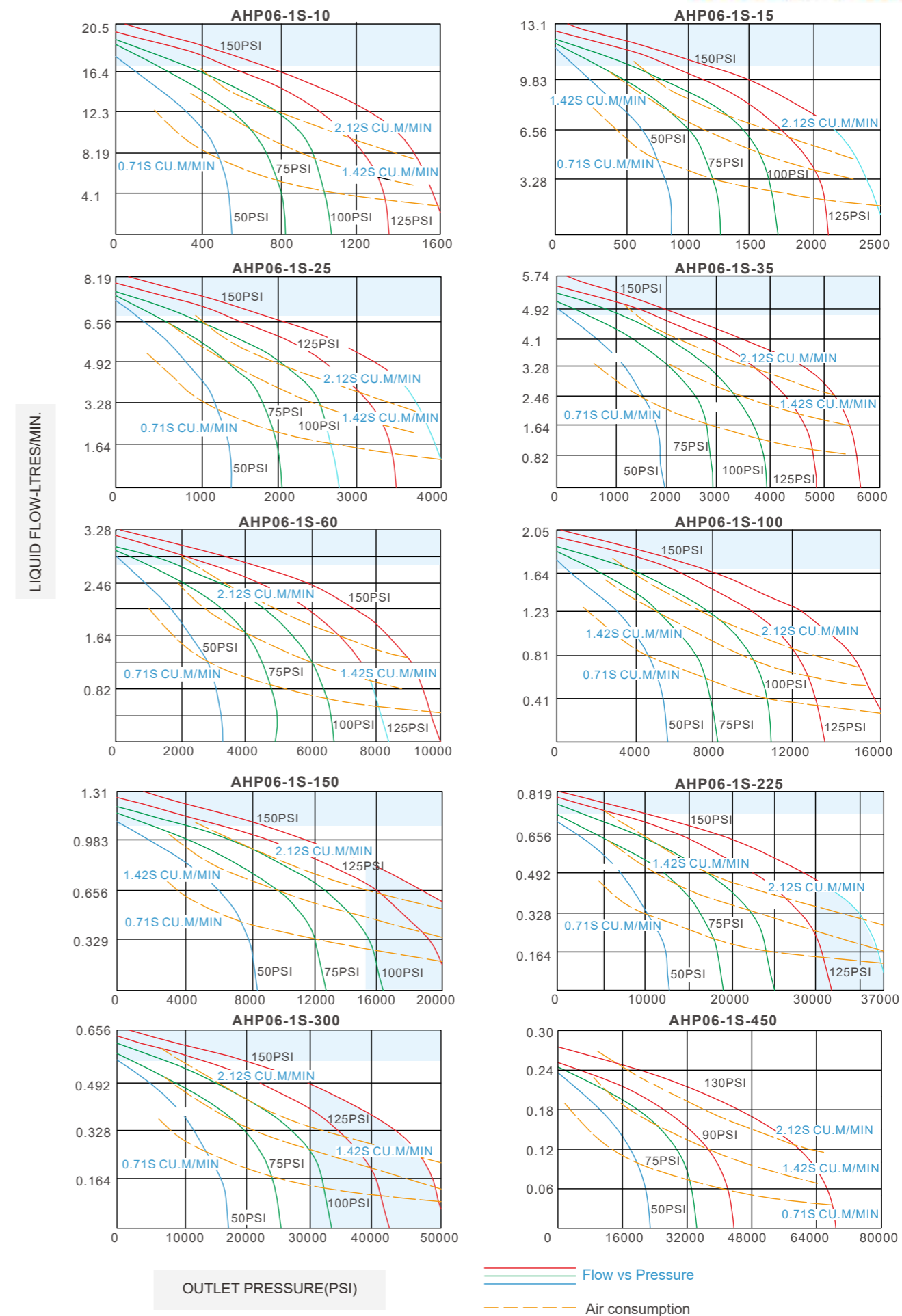

AHP06 Series ▶ Double Drive Single Acting

▶ Features

- Choice of 9 ratios.
- Flows to 19.9 L/min.
- Choice of wetted materials.
- Pressures to 75,000 psi(5171 bar).
- Drive pressure 30 to 150 psi (2 to 10.3 bar).



▶ Performance and Specification

Pump Model code	Max.Out Press	Actual Ratio	Dis./Cycle	Max.Flow	Inlet Port	Outlet Port	Air Drive Port
AHP06-2S-20	3200psi(22.1MPa)	27:1	66.4mL	19.9L/min	1"FNPT	1/2"FNPT	3/4"FNPT
AHP06-2S-30	4800psi(33.1MPa)	35:1	44.3mL	13.3L/min	1"FNPT	1/2"FNPT	3/4"FNPT
AHP06-2S-50	8000psi(55.1MPa)	60:1	26.6mL	8L/min	1/2"FNPT	1/2"FNPT	3/4"FNPT
AHP06-2S-70	11000psi(75.9MPa)	90:1	19.0mL	5.7L/min	1/2"FNPT	1/2"FNPT	3/4"FNPT
AHP06-2S-120	19000psi(131MPa)	144:1	11.0mL	3.3L/min	1/2"FNPT	1/2"FNPT	3/4"FNPT
AHP06-2S-200	33000psi(227.6MPa)	240:1	6.7mL	1.5L/min	1/2"FNPT	3/8"HF	3/4"FNPT
AHP06-2S-300	50000psi(344.8MPa)	360:1	4.5mL	1L/min	1/2"FNPT	3/8"HF	3/4"FNPT
AHP06-2S-450	70000psi(482.8MPa)	540:1	3.0mL	0.7L/min	1/2"FNPT	1/4"HF	3/4"FNPT
AHP06-2S-600	75000psi(517.2MPa)	720:1	2.3mL	0.5L/min	1/2"FNPT	1/4"HF	3/4"FNPT

HF means female high pressure connection, The max outlet pressure is based on the air drive pressure at 125psi (0.86MPa); The max flow rate is based on outlet pressure at 0 psi (working empty) .

▶ Dimensions

in.(mm)

AHP06-2S-20~30 Pumps

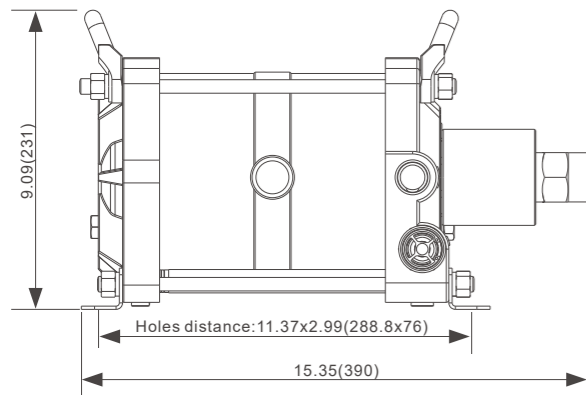

AHP06-2S-50~600 Pumps

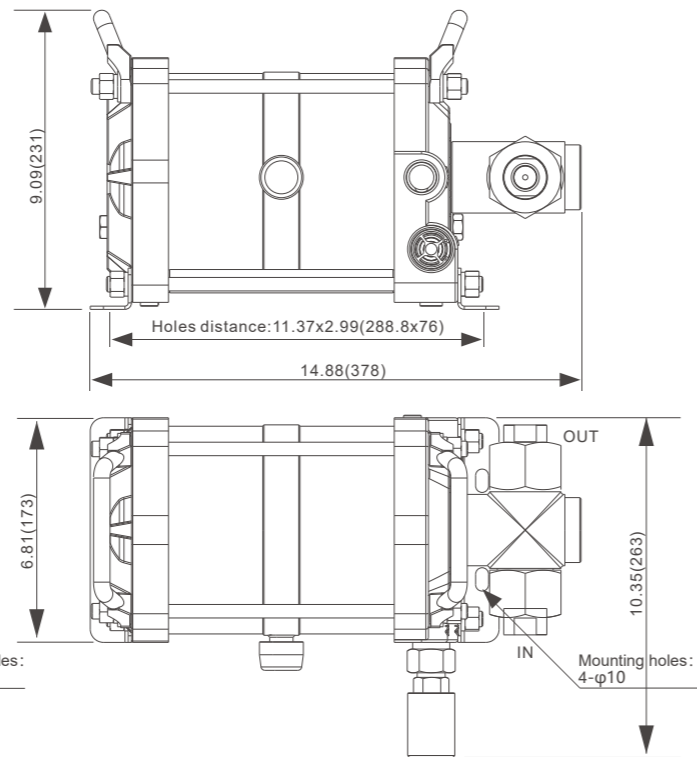

▶ Performance Curves

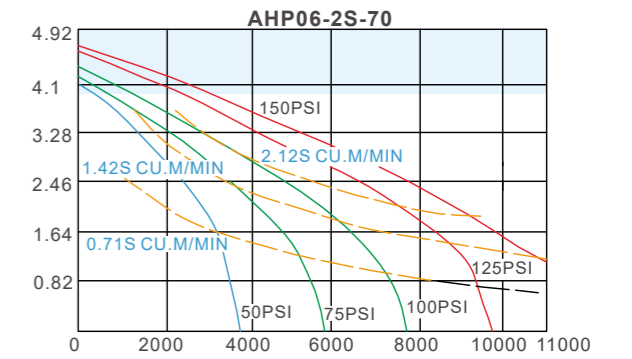
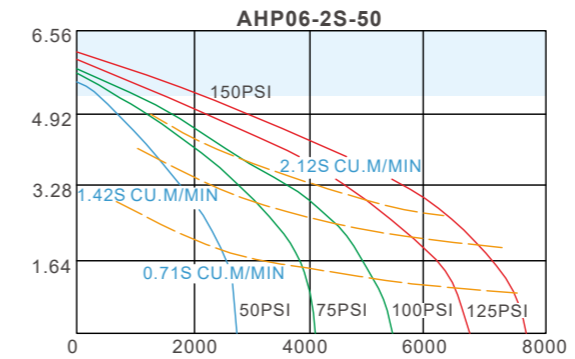
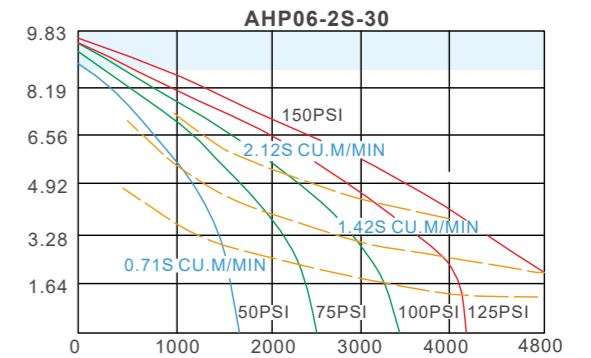
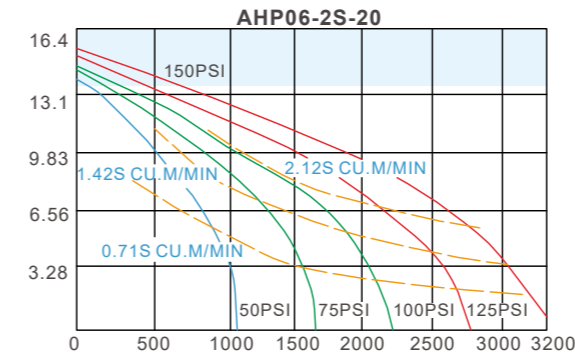

LIQUID FLOW-LITRES/MIN.

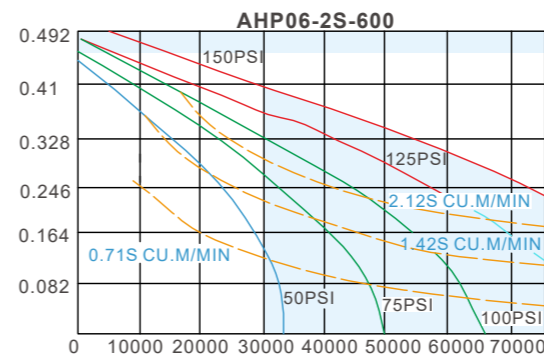
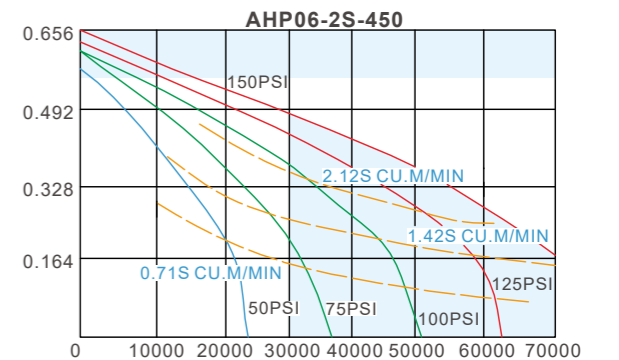
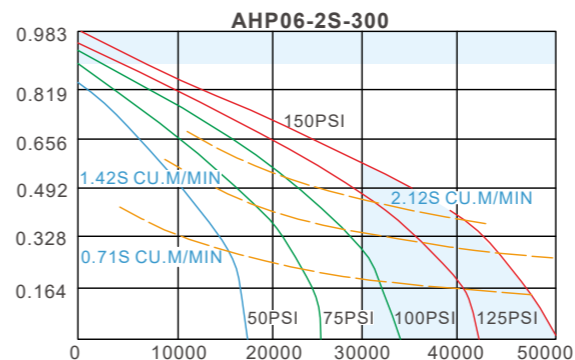
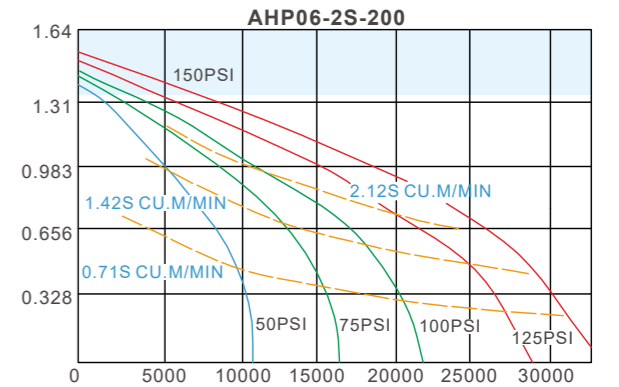
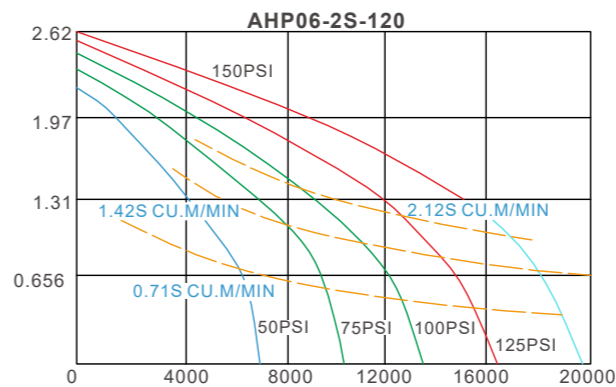

OUTLET PRESSURE(PSI)

— Flow vs Pressure

- - - Air consumption

Note: The shaded area in the diagram indicates excessive circulation rate or pressure. Use intermittently.

AHP06 Series ▶ Triple Drive Single Acting

▶ Features

- Choice of 3 ratios.
- Flows to 0.41 L/min.
- Choice of wetted materials.
- Pressures to 100,000 psi(6896 bar).
- All Hydraulic fluids, water(plain or DI), solvents, mild chemicals, liquefied gases.



▶ Performance and Specification

Pump Model code	Max.Out Press	Actual Ratio	Dis./Cycle	Max.Flow	Inlet Port	Outlet Port	Air Drive Port
AHP06-3S-675	70000psi(482.8MPa)	800:1	3.0mL	0.41L/min	1/2"NPT	1/4"HF	3/4"FNPT
AHP06-3S-900	75000psi(517.2MPa)	1000:1	2.3mL	0.33L/min	1/2"NPT	1/4"HF	3/4"FNPT
AHP06-3S-1350	100000psi(690MPa)	1500:1	1.5mL	0.20L/min	1/2"NPT	1/4"HF	3/4"FNPT

"SF" means female high pressure connection, AHP06-3S-675 maximum driving pressure: 88 psi, AHP06-3S-900 maximum driving pressure: 75 psi, AHP06-3S-1350 maximum driving pressure: 67 psi. The max flow rate is based on outlet pressure at 0 psi (working empty) [Pumps in this series include isolation by default].

▶ Dimensions

in.(mm)

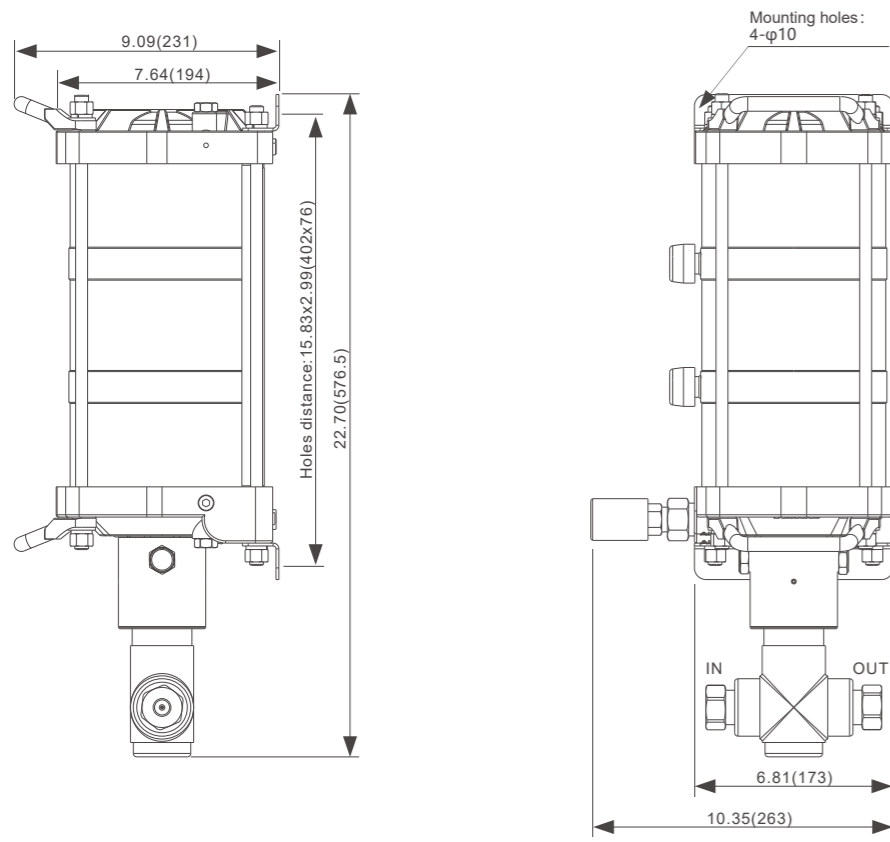

▶ Performance Curves

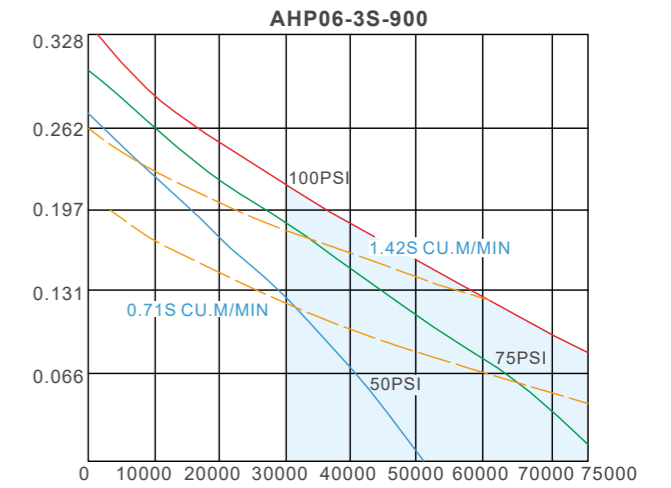
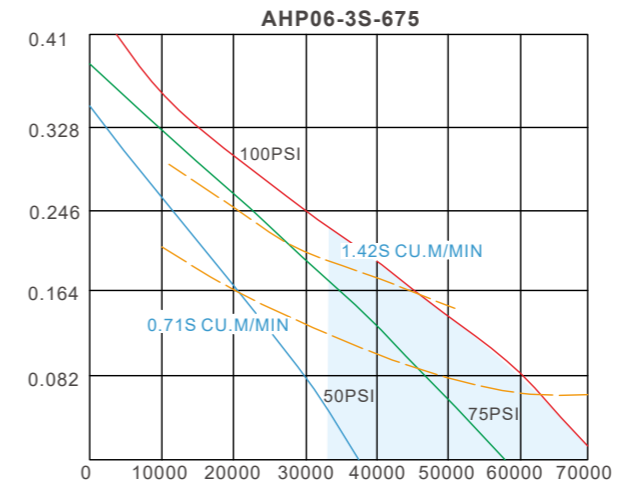

LIQUID FLOW-LTRES/MIN.

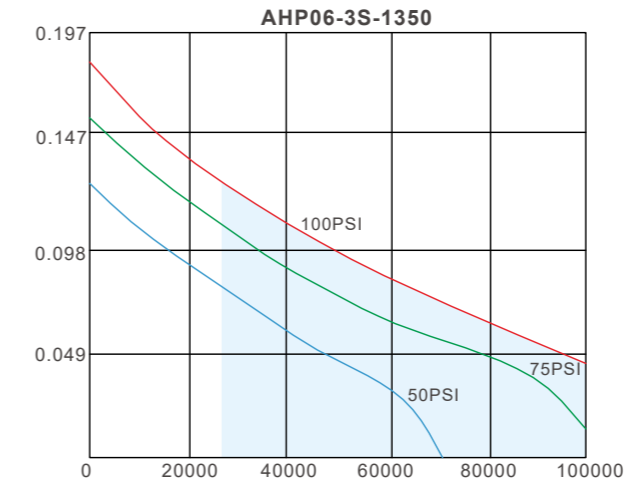

OUTLET PRESSURE(PSI)

Flow vs Pressure
Air consumption

Note: The shaded area in the diagram indicates excessive circulation rate or pressure. Use intermittently.

AHP06 Series ▶ Single Drive Double Acting

▶ Features

- Choice of 8 ratios.
- Flows to 29.9 L/min.
- Choice of wetted materials.
- Pressures to 20,000 psi(1379 bar).
- Drive pressure 30 to 150 psi (2 to 10.3 bar).



▶ Performance and Specification

Pump Model code	Max.Out Press	Actual Ratio	Dis./Cycle	Max.Flow	Inlet Port	Outlet Port	Air Drive Port
AHP06-1D-4	1200psi(8.3MPa)	4.6:1	328mL	52.4L/min	1/2"FNPT	1/2"FNPT	3/4"FNPT
AHP06-1D-10	1600psi(11MPa)	14:1	133mL	29.9L/min	1"FNPT	1/2"FNPT	3/4"FNPT
AHP06-1D-15	2400psi(16.6MPa)	18:1	89mL	19.9L/min	1/2"FNPT	1/2"FNPT	3/4"FNPT
AHP06-1D-25	4000psi(27.6MPa)	30:1	53.6mL	11.9L/min	1/2"FNPT	1/2"FNPT	3/4"FNPT
AHP06-1D-35	5700psi(39.3MPa)	45:1	38mL	8.6L/min	1/2"FNPT	1/2"FNPT	3/4"FNPT
AHP06-1D-60	9800psi(67.6MPa)	72:1	22mL	4.9L/min	1/2"FNPT	1/2"FNPT	3/4"FNPT
AHP06-1D-100	16500psi(113.8MPa)	120:1	13.4mL	3.0L/min	1/2"FNPT	1/2"FNPT	3/4"FNPT
AHP06-1D-150	20000psi(137.9MPa)	180:1	9mL	2.0L/min	1/2"FNPT	3/8"HF	3/4"FNPT

HF means female high pressure connection, The max outlet pressure is based on the air drive pressure at 125psi (0.86MPa); The max flow rate is based on outlet pressure at 0 psi (working empty) .

▶ Dimensions

in.(mm)

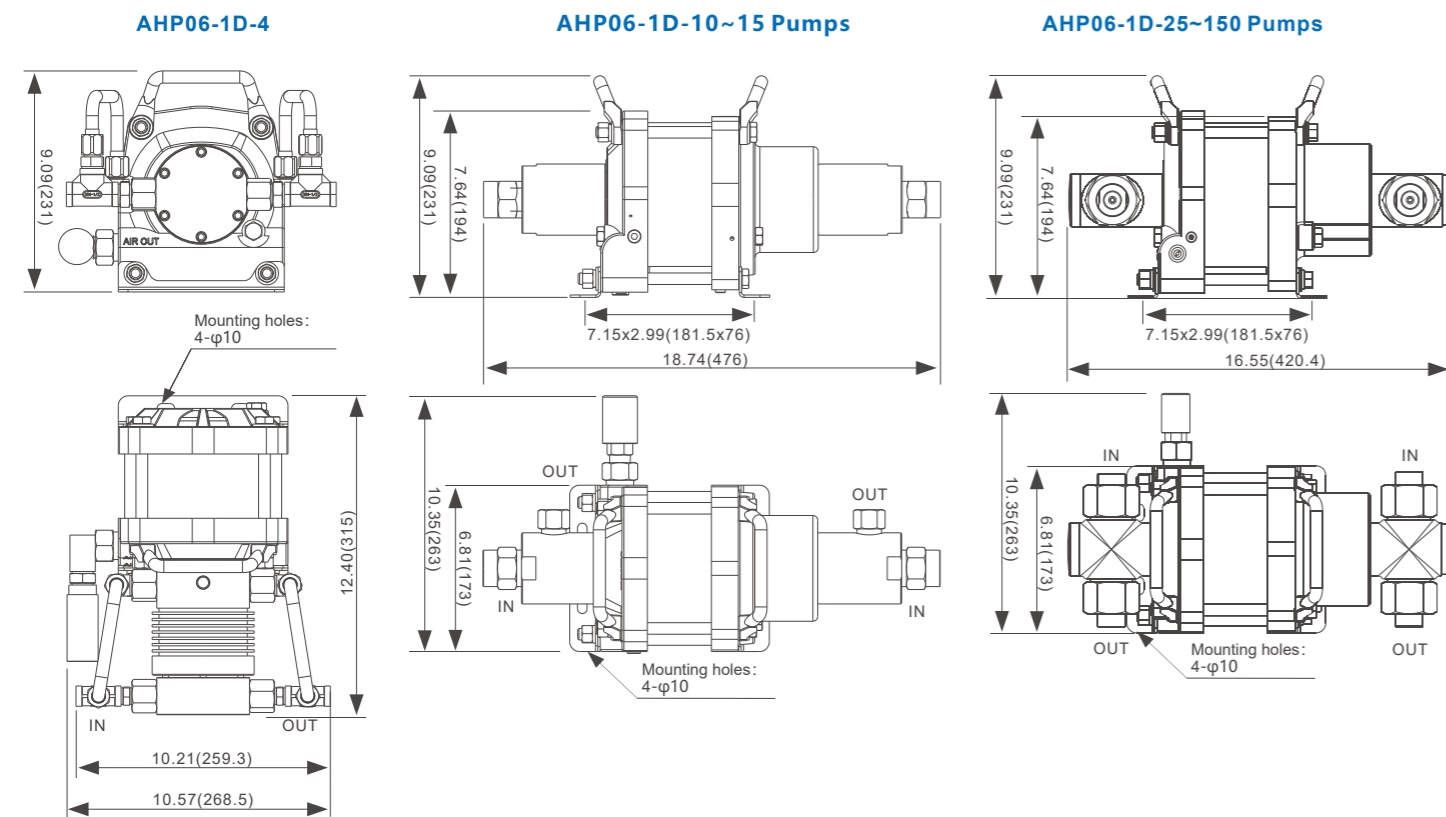

▶ Performance Curves

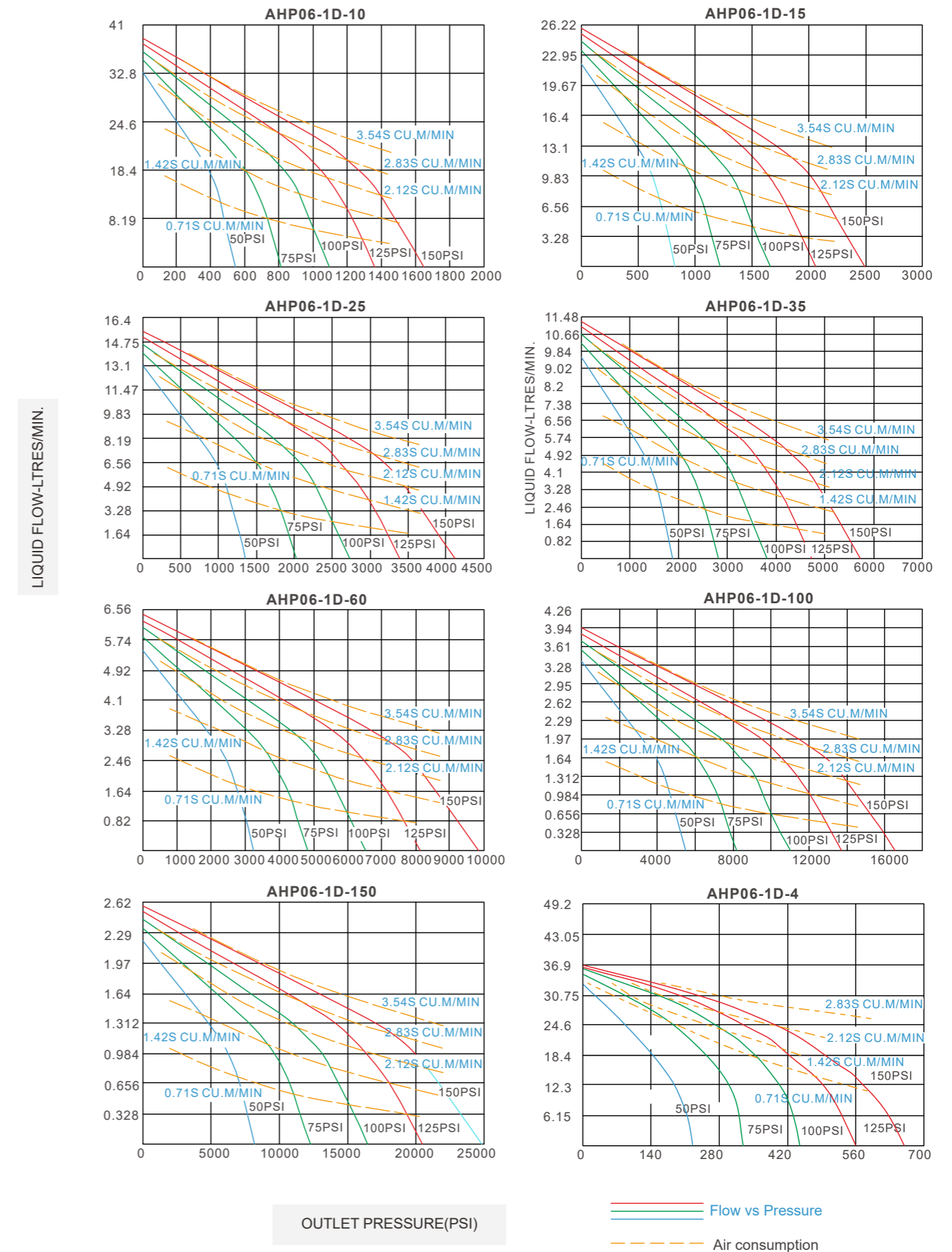

AHP06 Series ▶ Double Drive Double Acting

▶ Features

- Choice of 4 ratios.
- Flows to 8.6 L/min.
- Choice of wetted materials.
- Pressures to 50,000 psi(3448 bar).
- Drive pressure 30 to 150 psi (2 to 10.3 bar).



▶ Performance and Specification

Pump Model code	Max.Out Press	Actual Ratio	Dis./Cycle	Max.Flow	Inlet Port	Outlet Port	Air Drive Port
AHP06-2D-70	11000psi(75.9MPa)	90:1	38mL	8.6L/min	1/2"FNPT	1/2"FNPT	3/4"FNPT
AHP06-2D-120	19000psi(131MPa)	144:1	22mL	4.9L/min	1/2"FNPT	1/2"FNPT	3/4"FNPT
AHP06-2D-200	33000psi(227.6MPa)	240:1	13.4mL	3.0L/min	1/2"FNPT	3/8"HF	3/4"FNPT
AHP06-2D-300	50000psi(344.8MPa)	360:1	9mL	2.0L/min	1/2"FNPT	3/8"HF	3/4"FNPT

HF means female high pressure connection, The max outlet pressure is based on the air drive pressure at 125psi (0.86MPa); The max flow rate is based on outlet pressure at 0 psi (working empty) .

▶ Dimensions

in.(mm)

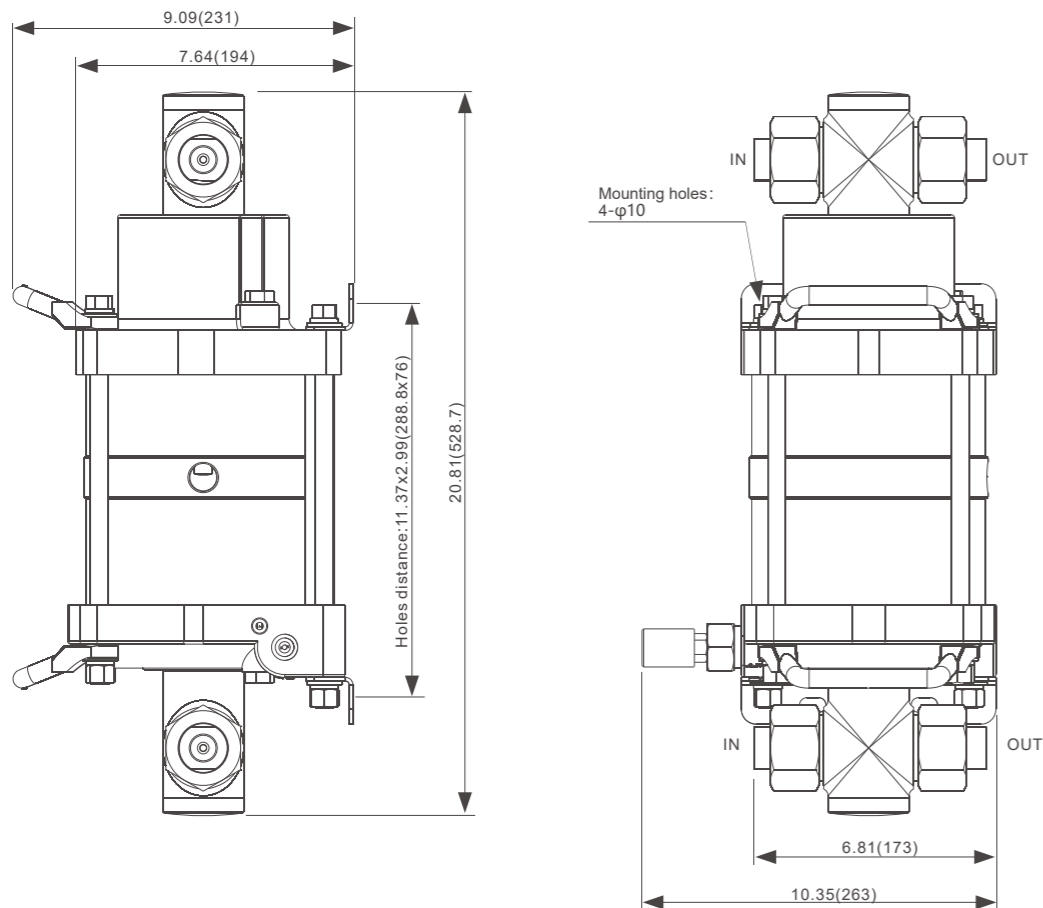

▶ Performance Curves

LIQUID FLOW-LTRES/MIN.

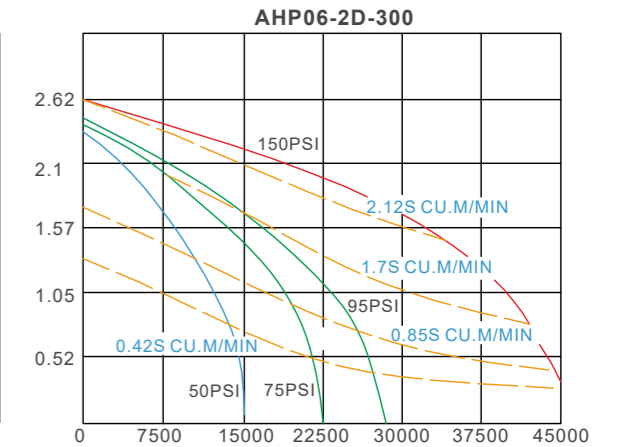
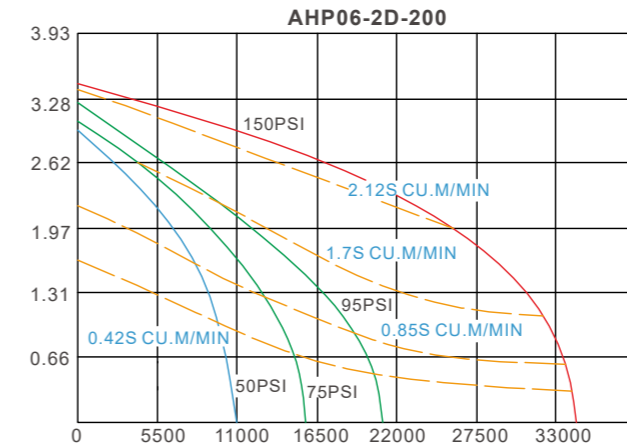
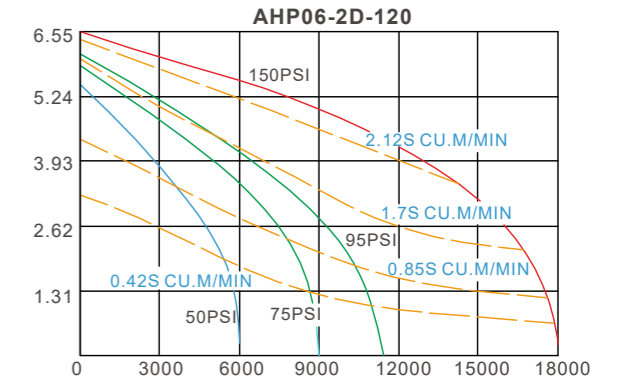
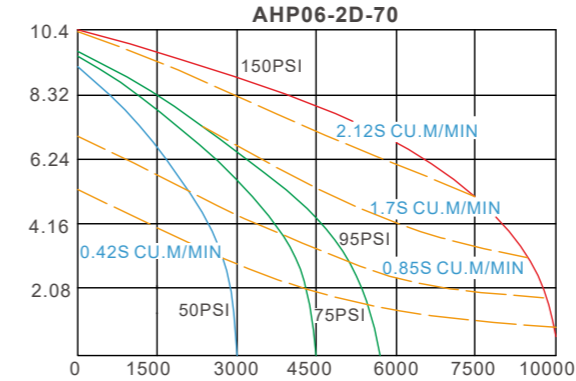

OUTLET PRESSURE(PSI)

— Flow vs Pressure
 — Air consumption

AHP06 Series ▶ Long Stroke Single Drive Double Acting

▶ Features

- Choice of 5 ratios.
- Flows to 132 L/min.
- Choice of wetted materials.
- Pressures to 10,000 psi(690 bar).
- Drive pressure 30 to 125 psi (2 to 8.6 bar).
- All Hydraulic fluids, water(plain or DI), solvents, mild chemicals, liquefied gases.



▶ Performance and Specification

Pump Model code	Max.Out Press	Actual Ratio	Dis./Cycle	Max.Flow	Inlet Port	Outlet Port	Air Drive Port
AHP06-1D-7L	1000psi(6.9MPa)	8.2:1	463mL	132L/min	1-1/4"FNPT	3/4"FNPT	3/4"FNPT
AHP06-1D-12L	1850psi(12.8MPa)	14:1	260mL	82.1L/min	1-1/4"FNPT	3/4"FNPT	3/4"FNPT
AHP06-1D-35L	4375psi(30.2MPa)	40:1	98mL	31L/min	1-1/4"FNPT	1/2"FNPT	3/4"FNPT
AHP06-1D-60L	7500psi(51.7MPa)	69:1	57mL	18.1L/min	1-1/4"FNPT	1/2"FNPT <td 3/4"FNPT	
AHP06-1D-100L	10000psi(69MPa)	120:1	32mL	10.7L/min	1-1/4"FNPT	1/2"FNPT	3/4"FNPT

The max outlet pressure is based on the air drive pressure at 125psi(0.86MPa); The max flow rate is based on outlet pressure at 0 psi (working empty) .

▶ Dimensions

in.(mm)

AHP06-1D-7L\12L

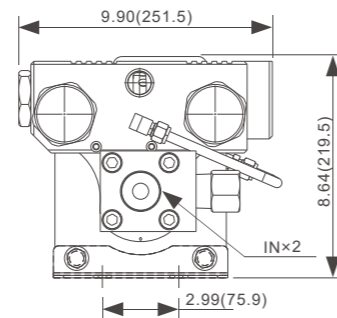
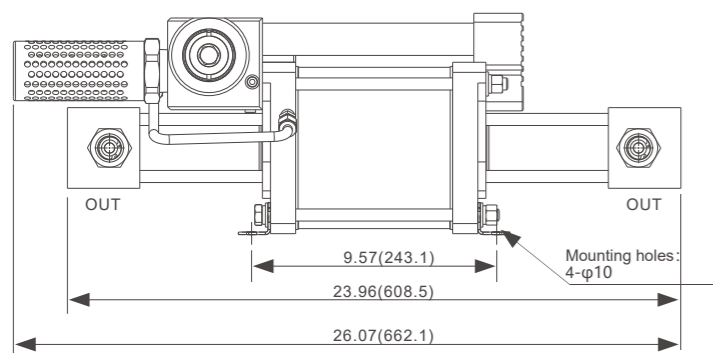

AHP06-1D-35L, 60L, 100L

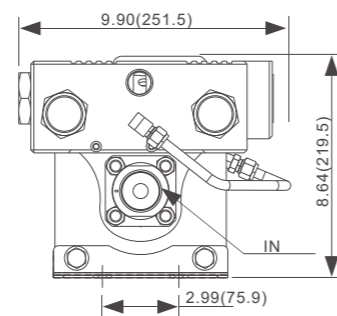
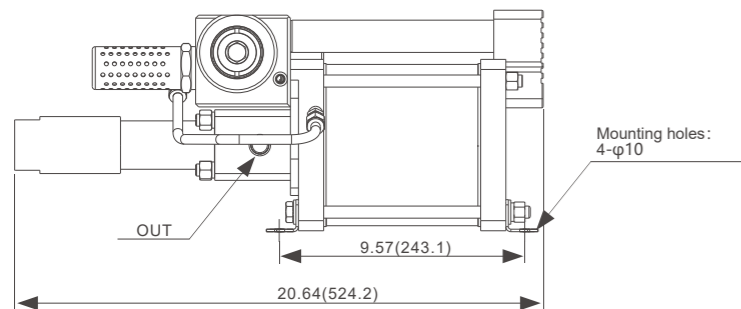

▶ Performance Curves

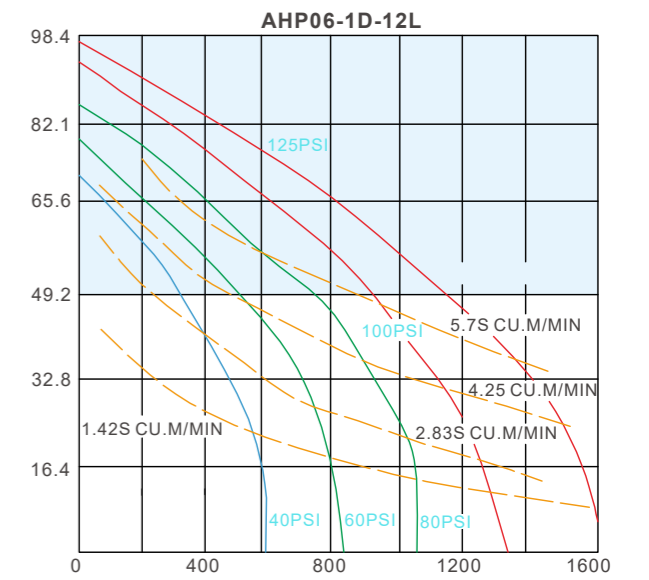
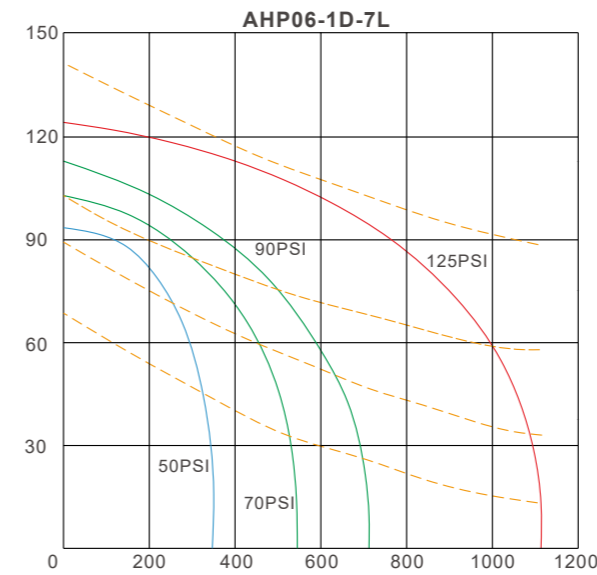

LIQUID FLOW-LITRES/MIN.

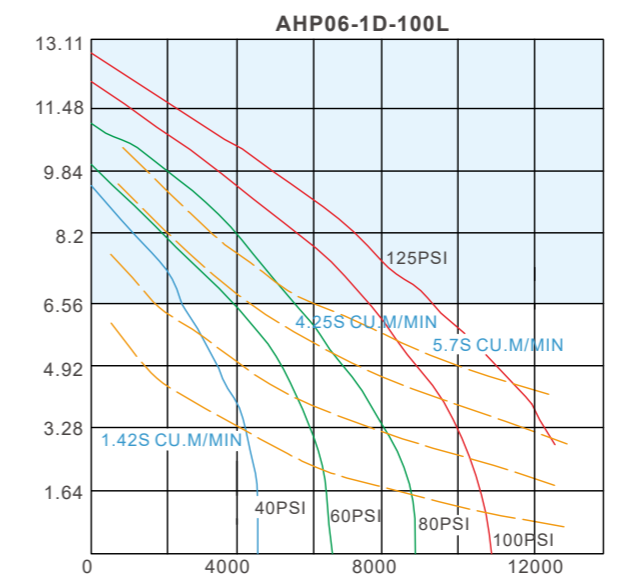
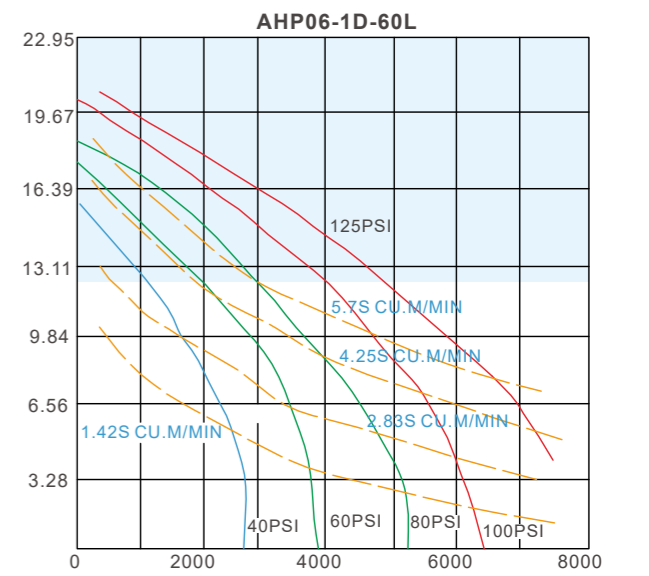
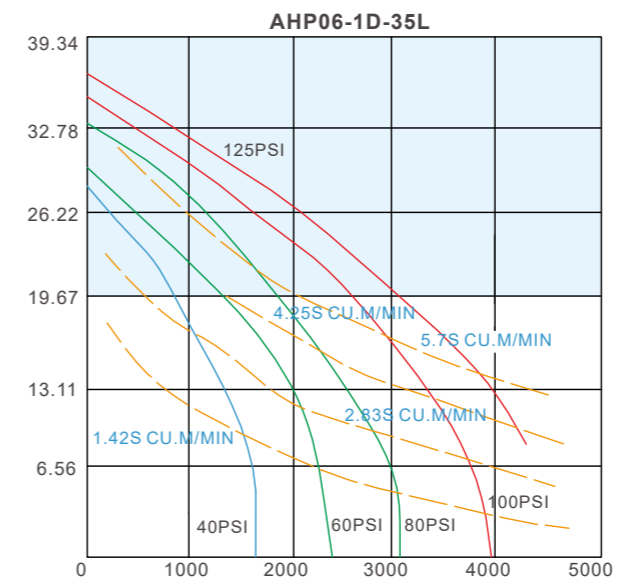

OUTLET PRESSURE(PSI)

- Flow vs Pressure
- - - Air consumption

Note: The shaded area in the diagram indicates excessive circulation rate or pressure. Use intermittently.

AHP10 Series ▶ Single Drive Double Acting

▶ Features

- Choice of 5 ratios.
- Flows to 45.5 L/min.
- Choice of wetted materials.
- Can be quickly repaired.
- Output pressures to 325,00 psi (2241 bar).
- Drive pressure 30 to 125 psi (2 to 8.6 bar).
- All Hydraulic fluids, water(plain or DI), solvents, mild chemicals, liquefied gases.



▶ Performance and Specification

Pump Model code	Max.Out Press	Actual Ratio	Dis./Cycle	Max.Flow	Inlet Port	Outlet Port	Air Drive Port
AHP10-1D-30	3750psi(25.9MPa)	38:1	320mL	45.5L/min	3/4"FNPT	3/4"FNPT	3/4"FNPT
AHP10-1D-60	7500psi(51.7MPa)	67:1	180mL	23.4L/min	3/4"FNPT	1/2"FNPT	3/4"FNPT
AHP10-1D-120	15000psi(103.4MPa)	125:1	98mL	12.7L/min	3/4"FNPT	9/16"HF	3/4"FNPT
AHP10-1D-180	22500psi(155.2MPa)	204:1	60.5mL	7.9L/min	3/4"FNPT	9/16"HF	3/4"FNPT
AHP10-1D-260	32500psi(224.1MPa)	304:1	40.5mL	5.3L/min	3/4"FNPT	9/16"HF	3/4"FNPT

HF means female high pressure connection, The max outlet pressure is based on the air drive pressure at 125psi (0.86MPa); The max flow rate is based on outlet pressure at 0 psi (working empty) .

▶ Dimensions

in.(mm)

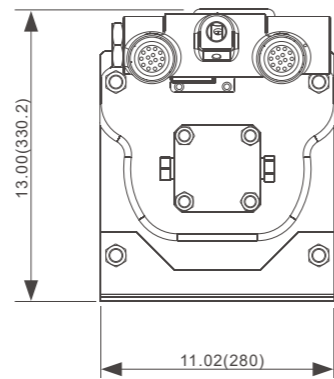
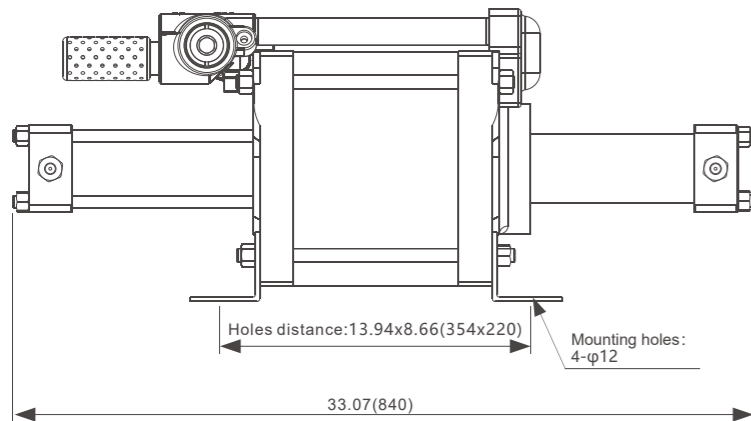

▶ Performance Curves

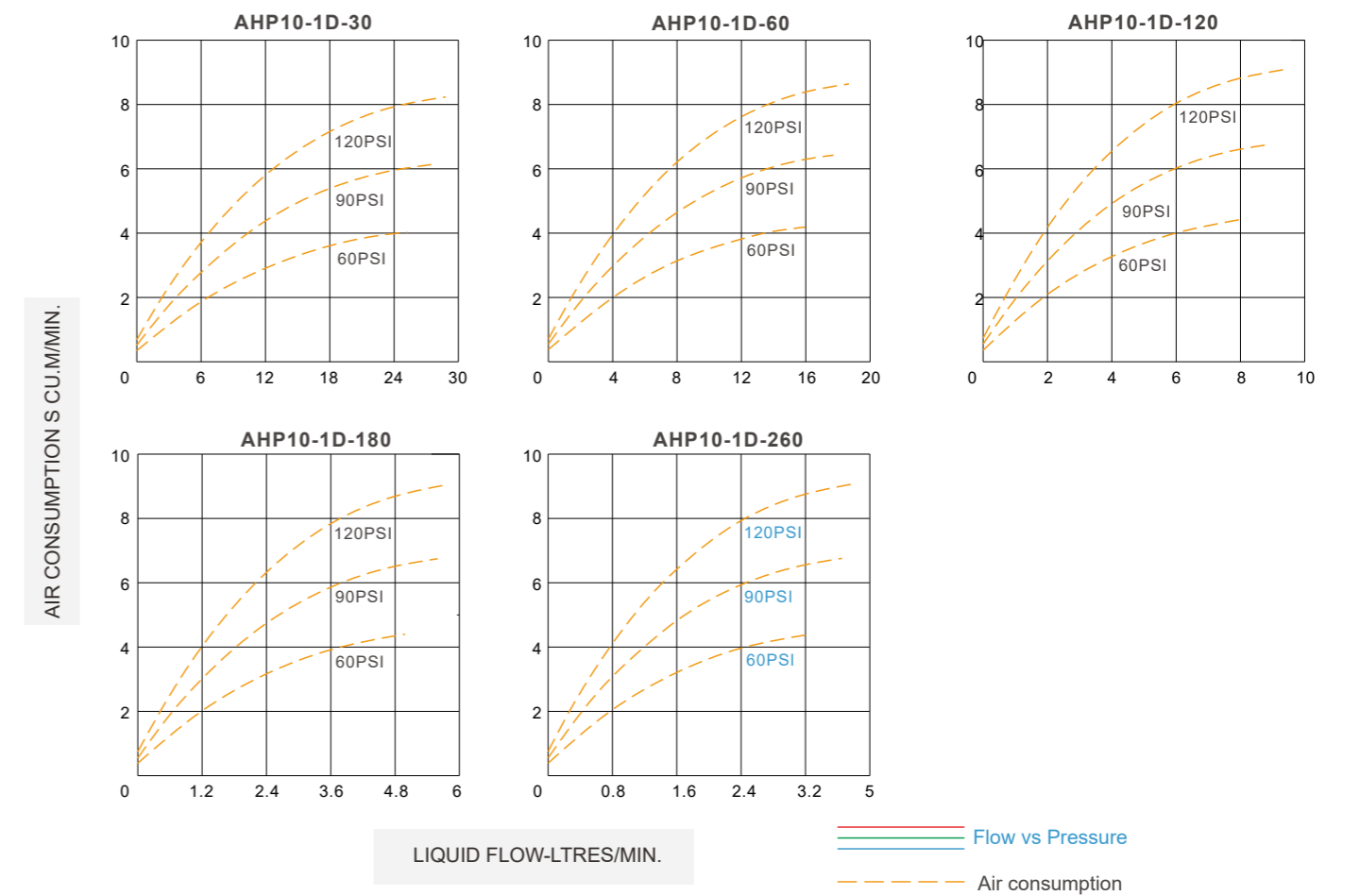
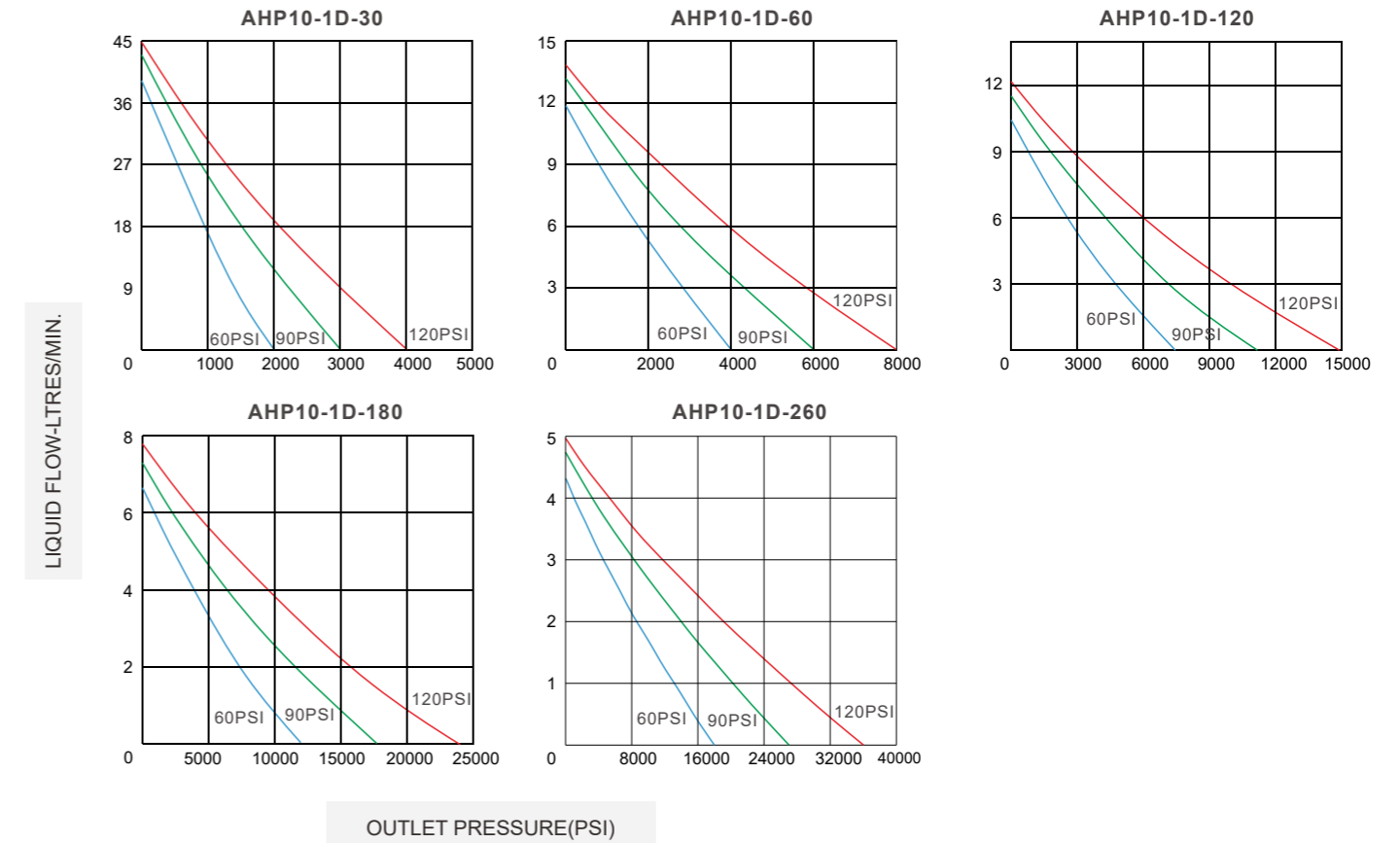

— Flow vs Pressure
 - - - Air consumption

AHP10 Series ▶ Double Drive Double Acting

▶ Features

- Choice of 5 ratios.
- Flows to 31.5 L/min.
- Choice of wetted materials.
- Can be quickly repaired.
- Output pressures to 650,00 psi (4482 bar).
- Drive pressure 10 to 125 psi (2 to 8.6 bar).
- All Hydraulic fluids, water(plain or DI), solvents, mild chemicals, liquefied gases.



▶ Performance and Specification

Pump Model code	Max.Out Press	Actual Ratio	Dis./Cycle	Max.Flow	Inlet Port	Outlet Port	Air Drive Port
AHP10-2D-60	7500psi(51.7MPa)	76:1	320mL	31.5L/min	3/4"FNPT	3/4"FNPT	3/4"FNPT
AHP10-2D-120	15000psi(103.4MPa)	134:1	180mL	16.2L/min	3/4"FNPT	1/2"FNPT	3/4"FNPT
AHP10-2D-240	30000psi(206.9MPa)	250:1	98mL	8.8L/min	3/4"FNPT	9/16"HF	3/4"FNPT
AHP10-2D-360	45000psi(310.3MPa)	408:1	60.5mL	5.5L/min	3/4"FNPT	9/16"HF	3/4"FNPT
AHP10-2D-520	65000psi(448.3MPa)	608:1	40.5mL	3.65L/min	1/2"FNPT	3/8"HF	3/4"FNPT

HF means female high pressure connection, The max outlet pressure is based on the air drive pressure at 125psi (0.86MPa); The max flow rate is based on outlet pressure at 0 psi (working empty) .

▶ Dimensions

in.(mm)

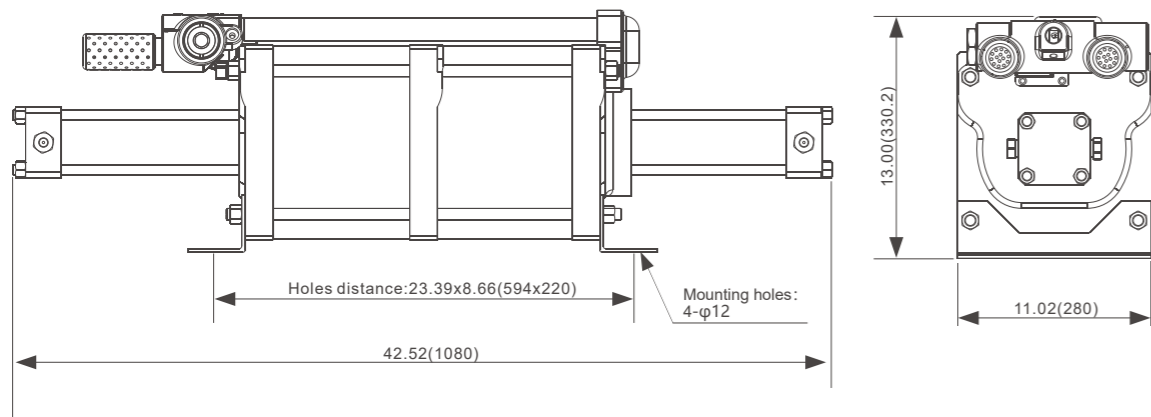

▶ Performance Curves

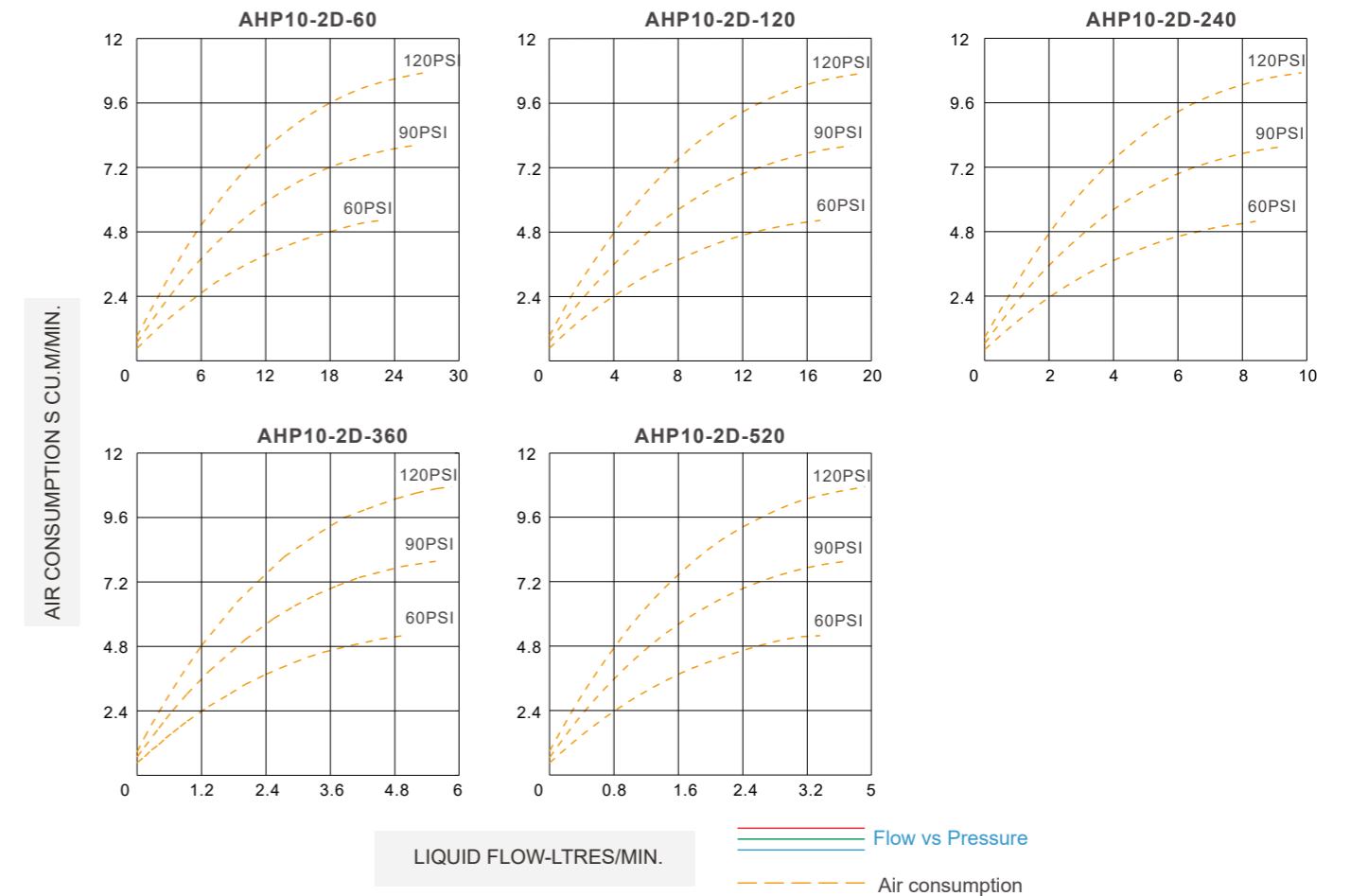
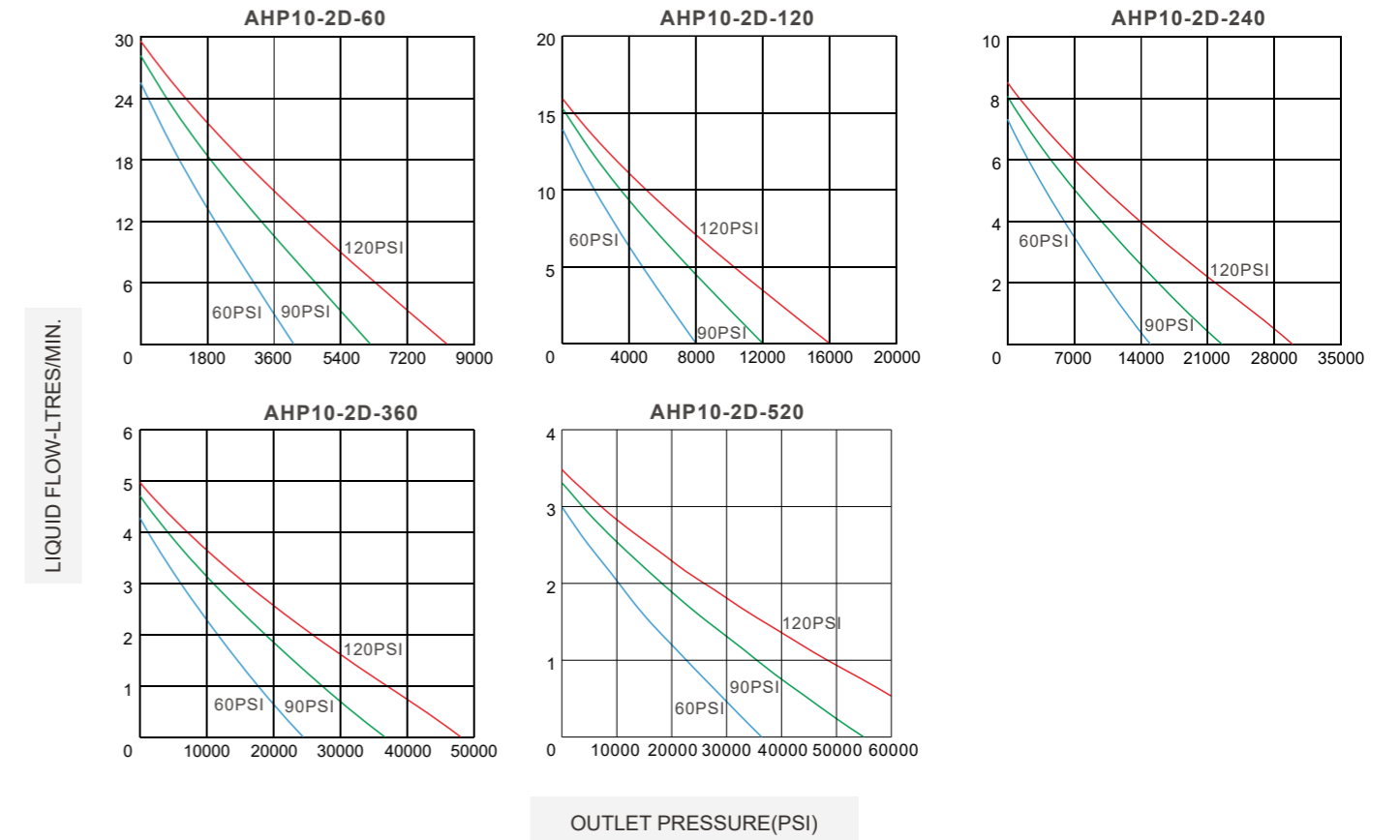

— Flow vs Pressure
 - - - Air consumption

ALG Series ▶ Single drive double stage(liquefied gas pump)

▶ Features

- Choice of 3 ratios.
- Choice of wetted materials.
- Can be quickly repaired.
- Lightweight with total weight between 6kg-11kg, easy to carry and convenient for operation.
- Pump requires no lubrication and is completely separated from the pressurizing medium, ensuring medium cleanliness.
- Suitable for most refrigerants such as R-113, etc, for pressurization, transfer, and recovery.



▶ Performance and Specification

Pa: Air Drive Pressure | Ps: Gas Inlet Pressure.

Pump Model code	Max. Rated Gas Supply	Min. Rated Gas Supply	Outlet Stall Press. Formula	Dis./Cycle	Inlet Port	Outlet Port	Air Drive Port
ALG04-1S-4	500psi	1/4ATM	4Pa	146mL	1/2"FNPT	1/2"FNPT	1/2"FNPT
ALG06-1T-4	1250psi	1/4ATM	4Pa+ps	164mL	1/2"FNPT	1/2"FNPT	3/4"FNPT
ALG06-1T-4D	1250psi	1/4ATM	4Pa+ps	164mL	1/2"FNPT	1/2"FNPT	3/4"FNPT

Sealing materials for the high-pressure section are optional; refer to the compatibility recommendation table for details.

▶ Dimensions

in.(mm)

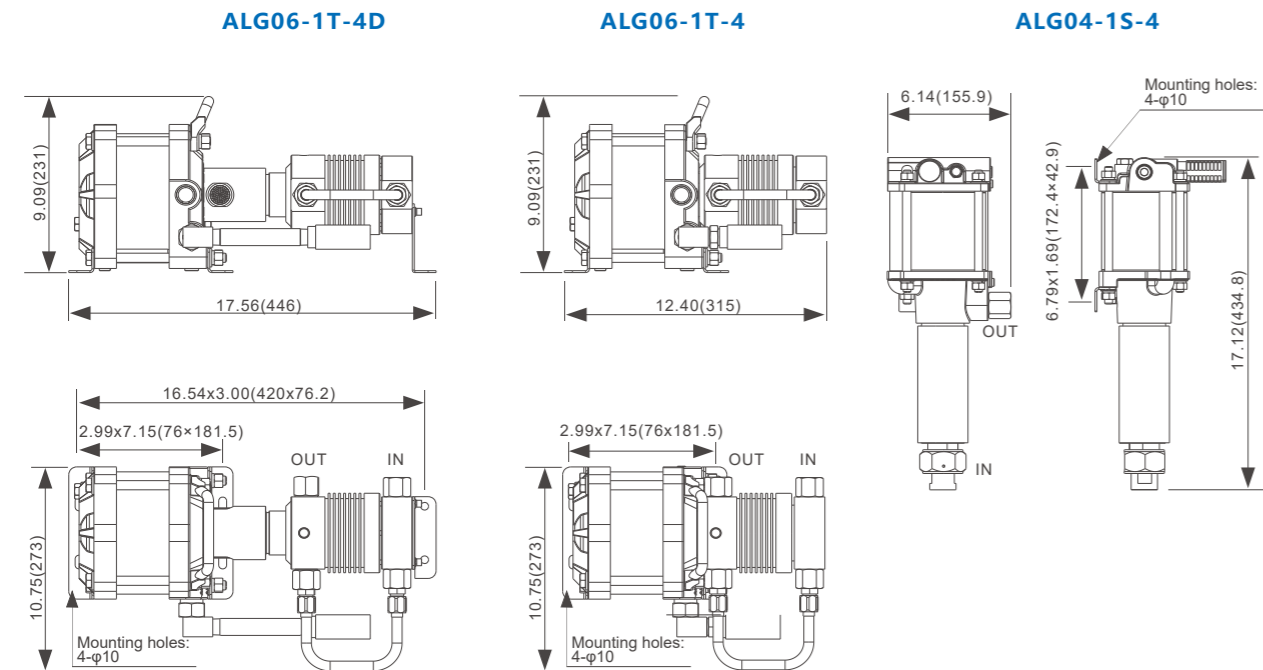

Approximate Performance Capability

Model	Vapor with constant output resistance of			
	15psi and inlet falling from		250psi and inlet falling from	
	15psi(1bar) ▶ 0psi	0psi ▶ 27" HG	50psi (3bar) ▶ 0psi	0psi ▶ 23" HG
ALG04-1S-4	Averages 0.0396Nm ³ /min	Averages 0.3115Nm ³ /min	Averages 0.0425Nm ³ /min	Averages 0.3115Nm ³ /min
ALG06-1T-4	Averages 0.0425Nm ³ /min	Averages 0.4248Nm ³ /min	Averages 0.0453Nm ³ /min	Averages 0.3964Nm ³ /min

▶ Performance Curves

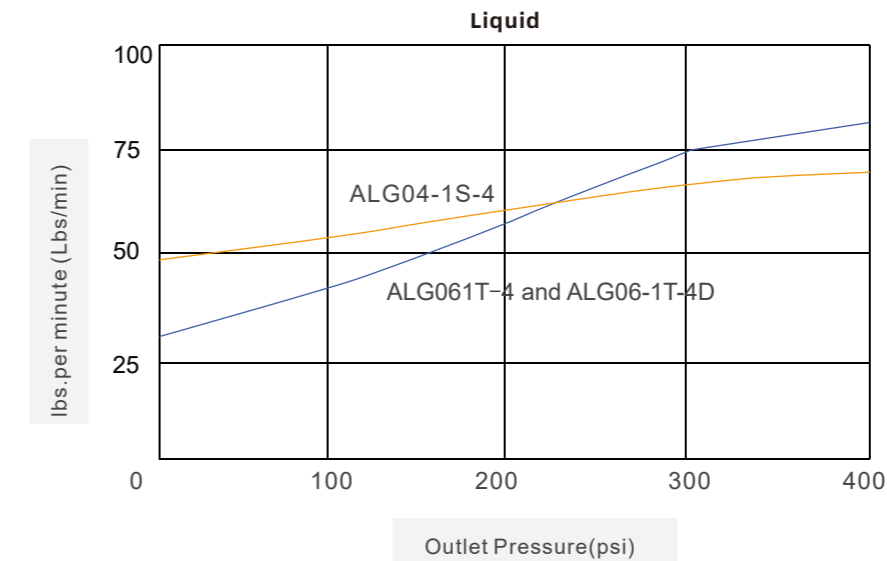

1. Air Drive Input: the data from the curve is based on air drive approximately 100 psi (7 bar) at 40 scfm (1.132 Nm³/min). Smaller-capacity air compressors will produce proportionally lower output flow rate.

2. Suction of Plumbing: the data from the curve assumes inlet pipe size 3/8"NPT without any restriction. Under a lot of refrigerant recovery applications, it can not avoid the severe restriction of inlet supply and will make the pump work empty reducing outlet flow rate.

3. Recommend to install safety and relief valves at the downstream since either pump at stall is capable of intensifying outlet pressures beyond normal refrigerant piping and receiving working pressure.

Actual flow rates will be subject to the liquid or vapor phase of the refrigerants.

Compatibility Table

Refrigerant	O-Ring Compatibility	Recommended Models
R-12, R-22, R-32, R-123, R-134A, R-1230	氟丁橡胶	ALG06-1S-4,ALG06-1T-4,ALG06-1T-4D
R-254, R-290, R-404, R-407, R-410, R-500		
R-502, FM200, HFO-1234YF	丁晴橡胶	ALG04-1S-4-2,ALG06-1T-4-2,ALG06-1T-4D-2
R-113, R-114, R-124, R-142		
R-23, R-112, R-143	氟橡胶	ALG04-1S-4-3,ALG06-1T-4-3,ALG06-1T-4D-3